



BULL OUTDOOR PRODUCTS
24 INCH PEDESTAL CART BOTTOM
OWNERS MANUAL
MODEL #69500
FOR USE WITH BULL 24" GRILL

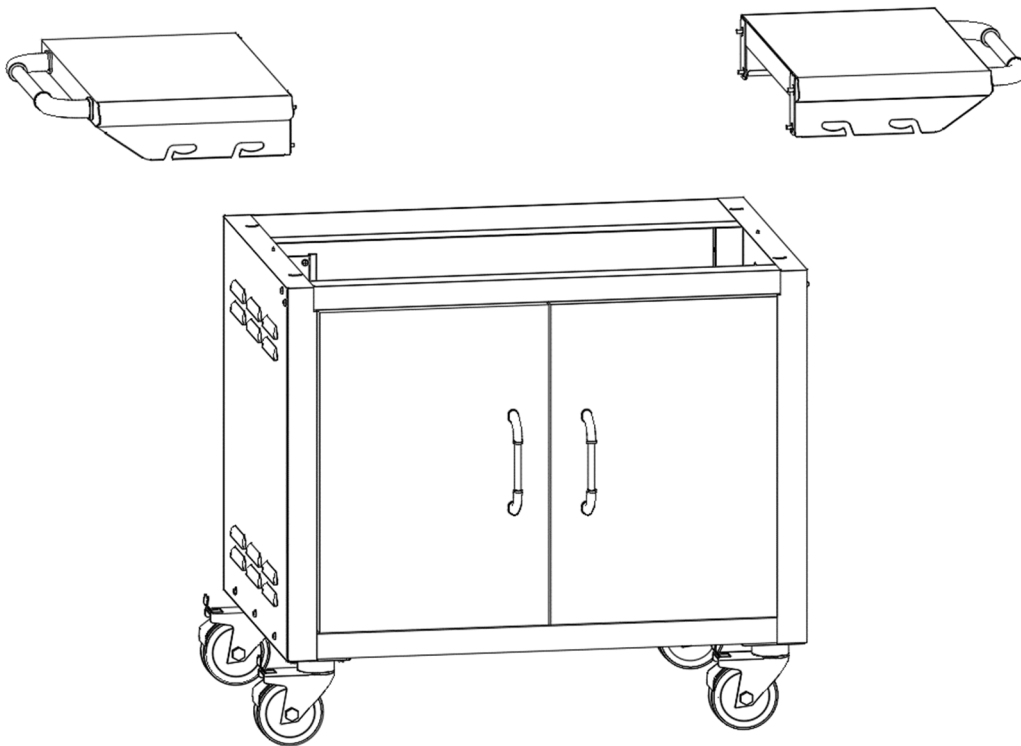



TABLE OF CONTENTS	PAGE#2
REGISTERING YOUR CART	
REPLACEMENT PART ORDERING INSTRUCTIONS	3
REPLACEMENT PARTS LIST AND ILLUSTRATION	4
CART ASSEMBLY HARDWARE	5
ASSEMBLY INSTRUCTIONS	
SETTING UP CART BODY TO INSTALL CASTERS	
INSTALLING CASTERS	6
INSTALLING DOOR HANDLES	
PREPARING GRILL HEAD FOR INSTALLATION TO CART	7
INSTALLING GRILL HEAD TO CART	8
INSTALLING SHELVES TO GRILL	9
LIQUID PROPANE SAFETY GUIDELINES	10
LIQUID PROPANE TANK INSTALL AND CONNECTION GRILL INSTRUCTIONS	11
CART LOCATION AND VENTILATION GUIDELINES	12
GRILL OPERATING INSTRUCTIONS	13
CART CLEANING AND MAINTENANCE	
LIQUID PROPANE SAFETY GUIDELINES WHEN CART IS NOT IN USE	14
LIMITED WARRANTY POLICY	15-17

We care about your safety, so please

- READ THE FOLLOWING INSTRUCTIONS CAREFULLY AND BE SURE YOUR GRILL CART IS PROPERLY INSTALLED, ASSEMBLED AND CARED FOR. FAILURE TO FOLLOW THESE INSTRUCTIONS MAY RESULT IN SERIOUS BODILY INJURY AND/OR PROPERTY DAMAGE. IF YOU HAVE QUESTIONS CONCERNING ASSEMBLY OR OPERATION, CONSULT YOUR DEALER OR APPLIANCE SERVICE REPRESENTATIVE.

- NOTE TO INSTALLER:

LEAVE THESE INSTRUCTIONS WITH THE CONSUMER AFTER INSTALLATION.

- NOTE TO THE CONSUMER:

RETAIN THESE INSTRUCTIONS FOR FUTURE REFERENCE.

***FOR WARRANTY PURPOSES, PLEASE RECORD YOUR MODEL NUMBER, SERIAL NUMBER, DATE OF PURCHASE & A COPY OF YOUR RECEIPT OR INVOICE IN THE BACK OF YOUR MANUAL.**



REGISTERING YOUR CART

To validate your Bull Limited Warranty, you must submit the completed the Warranty Registration Card within 90 days from the date of purchase. Registration can be completed on-line at <https://bullbbq.com/register> or by sending the completed Warranty Registration Card and copy of your Purchase Receipt or Invoice as proof of purchase to:
BULL OUTDOOR PRODUCTS, INC.
 1011 East Pine St.
 Lodi, CA 95240
 Attn: Warranty Service Center

For Warranty Claims or Replacement Parts ordering, please fill out the area provided below:

PRODUCT INFORMATION REFERENCE CARD

1) Model

Number _____

2) Date of Purchase _____

3) Copy of your Purchase Receipt or Invoice.

For Warranty Questions call Customer Service at (800) 521-2855

MODEL AND SERIAL NUMBER LOCATIONS

SIDES OF THE SHIPPING BOX

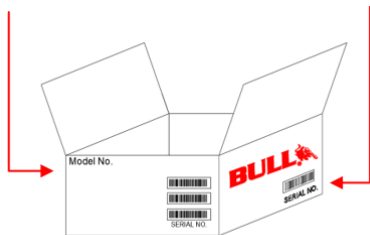

BACK SIDE OF THE CART

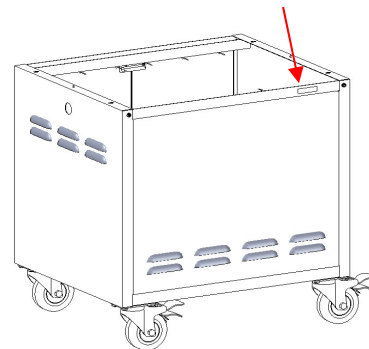

HOW TO ORDER REPLACEMENT PARTS

This is where your Product Information Reference Card will come in handy for supplying necessary info needed by your Bull Authorized Dealer to assure you get the correct part(s) for your Cart or additional accessories to keep your Cart in top working condition. If you don't have the card, you can still get the model number and serial number on upper right corner of the carts back side. That information is required for parts orders.

Please refer to your owner's manual parts list and illustration to identify what you need.

To Order Replacement Parts on-line go to: <https://www.bullbbq.com/buy-parts>

Ordering Parts by phone:

Bull is ready to help with two regional suppliers.
 open 8:00 am to 5:00 pm Monday through Friday.
 For the Western Region, call (800) 258-6810
 For the Eastern Region, call (800) 229-3056

INSPECT YOUR SIDE CART FOR ANY DAMAGE
AND CONTACT OUR SERVICE CENTER OR
LOCAL DEALER FOR REPLACEMENT OF ANY
DAMAGED PARTS. IF DAMAGED DO NOT
ATTEMPT INSTALLATION.

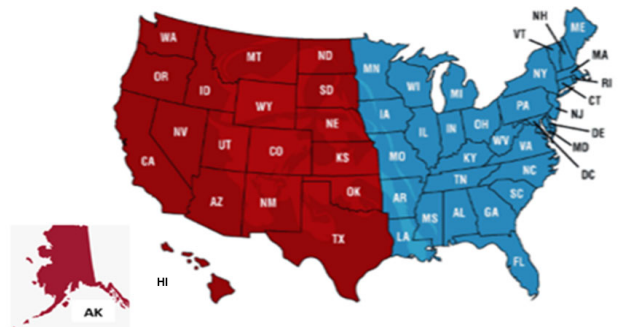

West Region

East Region

WARNING: Use of any part that is not factory authorized will void your warranty and may be dangerous.



REPLACEMENT PARTS LIST & ILLUSTRATION

MODEL # 69500

NOTE: Prior to assembly, use the parts list and illustration to verify all the parts are included. Inspect parts for any damage and contact your service center or local dealer for replacement of any damaged parts.

Do not attempt to assemble the cart if any of the parts are damaged.

ITEM # ON ILLUSTRATION	BULL PART #	DESCRIPTION	QTY
1	69200	LEFT DOOR PANEL	1
2	69201	RIGHT DOOR PANEL	1
3	16619 OR 16572	DOOR HANDLE	2
4	16515	DOOR HANDLE INSTALL KIT	2
5	16548	DOOR MAGNET	4
6	45520	SIDE SHELF HANDLE	2
7	69202	RIGHT SIDE SHELF	1
8	69203	LEFT SIDE SHELF	1
9	16514	SWIVEL CASTER	4
10	75321	TANK RETENTION BOLT	1

WARRANTY PERIOD FOR ALL PARTS IS 1 YEAR

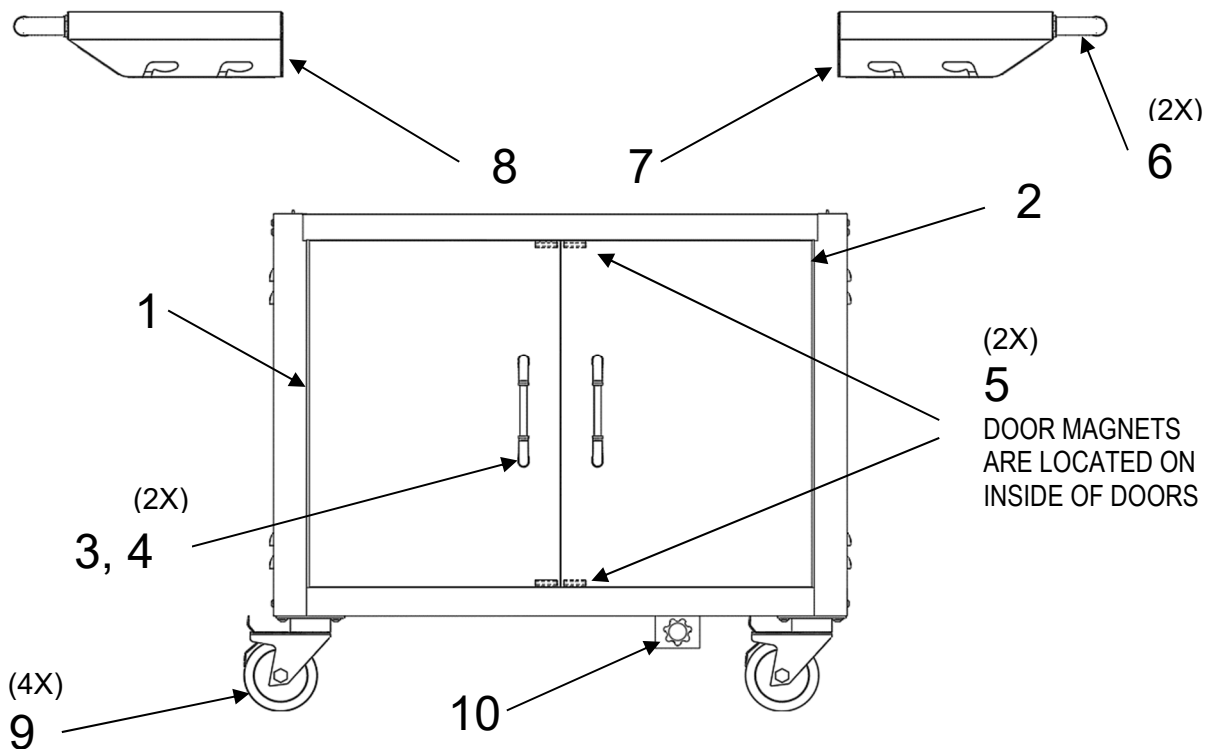

WARNING: Use of any part that is not factory authorized will void your warranty and may be dangerous.



CART ASSEMBLY HARDWARE

NOTE: Prior to assembly, use the list and illustration below to verify all the fasteners are included. If there are missing or damaged fasteners, contact your service center or local dealer for a replacement.

NOTE: Do not attempt assembling the cart until you have all the fasteners listed.

LETTER DESIGNATION ON ASSEMBLY ILLUSTRATIONS	DESCRIPTION SIZE	QUANTITY
A	HEX DRIVE BUTTON HEAD SCREW M5 x 12mm LONG	12
B	OVER SIZED FLAT WASHER M5 5.3 ID x 15 OD	12
C	SOC DRIVE PAN HEAD SCREW M8 X 20mm LONG	16
D	LOCK WASHER M8	16
E	FLAT WASHER M8.5 ID X 16 OD	16
F	ALLEN WRENCH M5	1
G	ALLEN WRENCH M8	1
H	PHILLIPS HEAD SCREW M6 X25mm	4
I	OVER SIZED FLAT WASHER M6	4

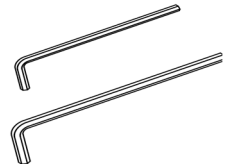
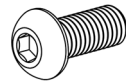
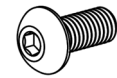



CART ASSEMBLY INSTRUCTIONS

For your safety, Bull recommends the assistance of another person when assembling larger and/or heavier items.

Setting up Pedestal Cart Body to install Castors.

The best way to do this is to flip the cart body upside down before installing per steps below:

- Take a piece of cardboard and lay it down on a flat surface level surface such, i.e., garage floor surface. The cardboard will help prevent scratching the cart while installing the castors.
- Take the Pedestal Cart Body, Castors, and Fasteners (C, D and E) out of the shipping box.
- Remove the lid on the floor panel that covers the hole when using a propane tank unless it is already taped in place. The doors mounted to the cart body will be held in place by magnetic catches.

TOP VIEW

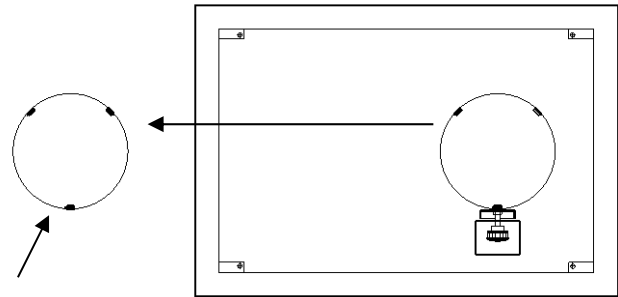

REMOVE LID ON BOTTOM OF CART BEFORE FLIPPING OVER TO MOUNT CASTORS

- Place the cart body upside down on the cardboard. You will see a mounting plate on each corner of the cart body. The mounting plates have 4 holes with nuts already attached.

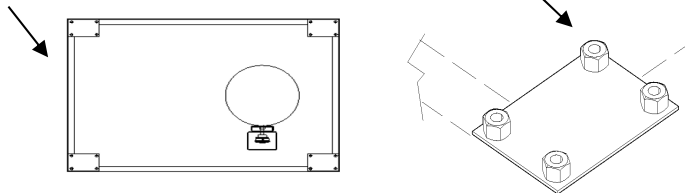

Installing Casters to Pedestal Cart Body

- Mount the casters to the flanges with fasteners 'C' 'D' and 'E'
- Note:** Lock washer must be between head of fastener and flat washer to work correctly per illustration.
- Note:** Initially, all the fasteners should only be 'finger tight'. Doing this makes assembly easier and reduces the chance of cross threading the screws. Failure to do so may cause irreparable damage to the caster screws.
- Use Allen wrench 'G' to tighten down the fasteners or if using a torque wrench the suggested setting is 13-15 in-lbs / 14-19 Nm.

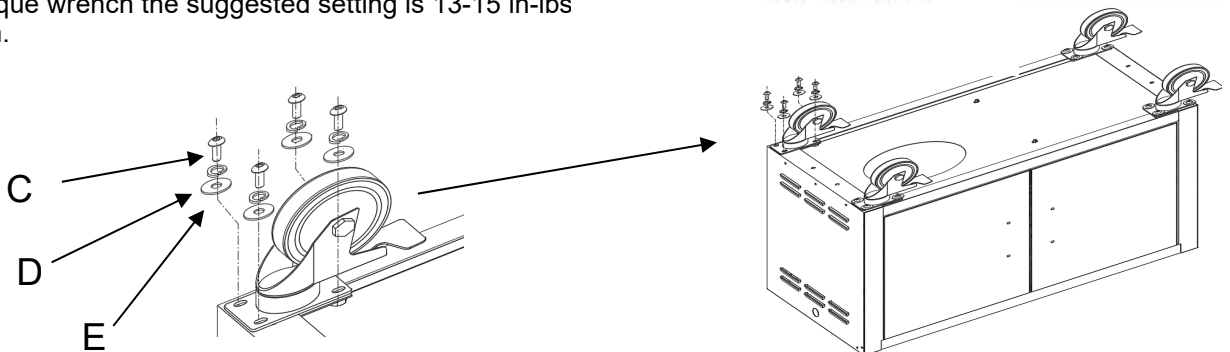
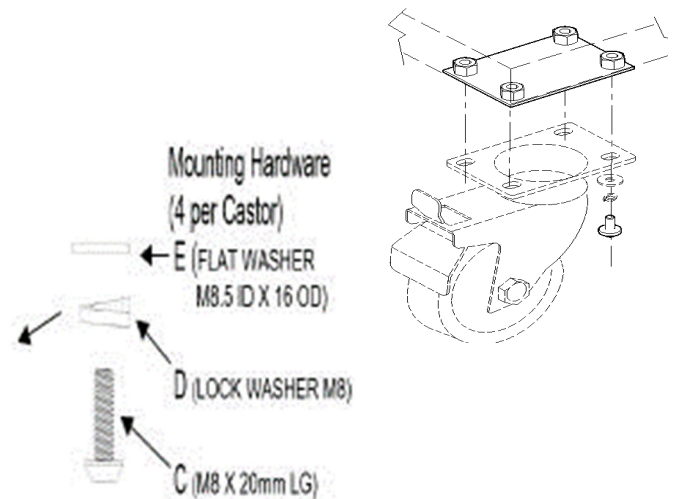

- Flip cart back to right side up and set the swivel casters wheels in the locked position to prevent the cart from moving and causing injury.





CART ASSEMBLY INSTRUCTIONS (CONTINUED)



IMPORTANT.

Before you begin this task

Set the swivel casters wheels in the **locked position** to prevent the cart from moving and causing injury.

DOOR HANDLE INSTALLATION

NOTE, FIRST CHECK TO SEE IF DOOR HANDLE IS LABELED AS METRIC IF SO USE ALTERNATE FASTENERS 'H' AND 'I' PROVIDED. OTHERWISE USE ITEM 4 DOOR HANDLE INSTALL KIT PROVIDED:

NOTE: YOUR INSTALL KIT PART NO. 16515 INCLUDES SPACERS, THEY CAN BE PUT ASIDE BECAUSE THE SPACERS HAVE BEEN PRE-INSTALLED FOR YOU PLEASE FOLLOW INSTRUCTIONS BELOW:

- 1) PLACE WASHER ON TO SCREW
- 2) INSERT INTO MOUNTING HOLE ON BACK SIDE OF DOOR TO ATTACH DOOR HANDLE ON OPPOSITE SIDE

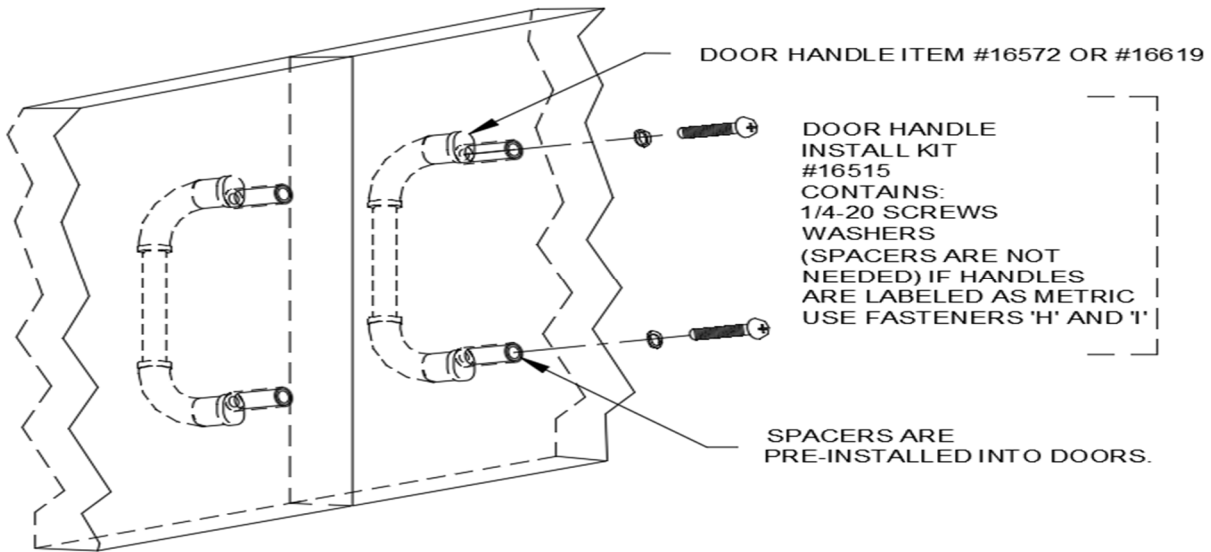

Installing the Grill Head to the Cart (Please read all instructions before starting)

Safety Guidelines:

- a. Set the swivel casters in the **locked position** to prevent the cart from moving and causing injury.
- b. **Warning: Do not attempt to lift the grill by yourself. (This step will require at least 2 people).**
- c. The grill will need to be carefully lifted and placed on to the cart. Before lifting the grill remove the items shown below to make it lighter prior to lifting.

Continue reading the rest of the instructions before lifting and positioning the grill.

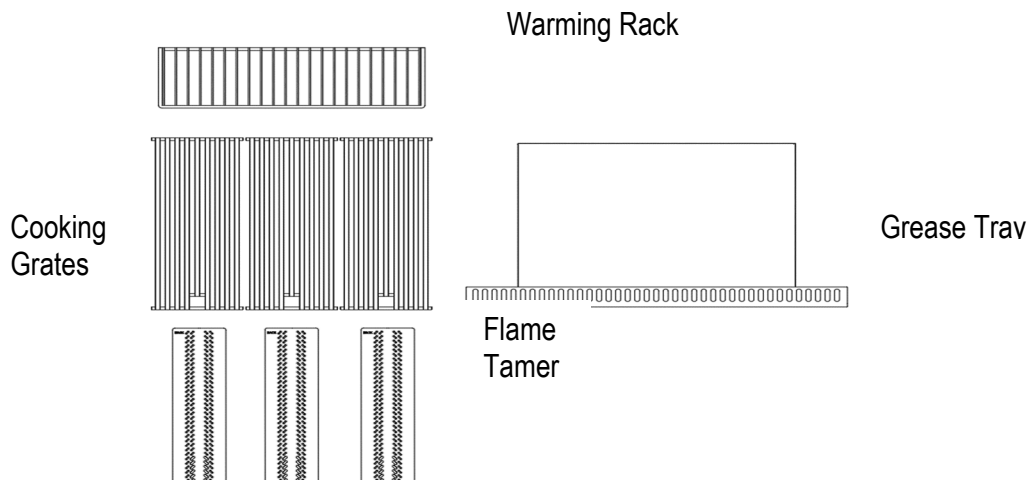



CART ASSEMBLY INSTRUCTIONS (CONTINUED)



Installing the Grill Head to the Cart

IMPORTANT: Set the swivel casters in the **locked position** to prevent the cart from moving and causing injury.

To complete you will need:

- 4 of fastener 'A' M5 x 12mm Long Hex Drive Button Head Screw
- 4 of washer 'B'
- Allen Wrench 'F'

Per illustration below, there are 3 mounting points on each of the left and right sides between grill on cart.

On the cart, each side has 2 clearance holes for the provided fasteners to bolt the grill on. In between those mounting holes on the cart is an alignment pin that engages a clearance hole on the grill.

On the grill, the left and right side of the grill has 3 mounting holes that have nuts mounted already to ease screwing the grill to the cart. The middle hole on each side is where the cart alignment pin is positioned.

REMEMBER: Do not attempt to lift grill by yourself. (This step will require at least 2 people).

- a. Carefully place the grill head on the cart and to the slots on the grill attaching with fasteners 'A' and 'B'
- b. **Note:** Initially, all the fasteners should only be 'finger tight'. Doing this makes assembly easier and reduces the chance of cross threading the screws. Failure to do so may cause irreparable damage to the assembly.
- c. Use Allen wrench 'F' to tighten down the fasteners, if using a torque wrench the suggested setting is 4.35 ft lbs./ 5 Nm.

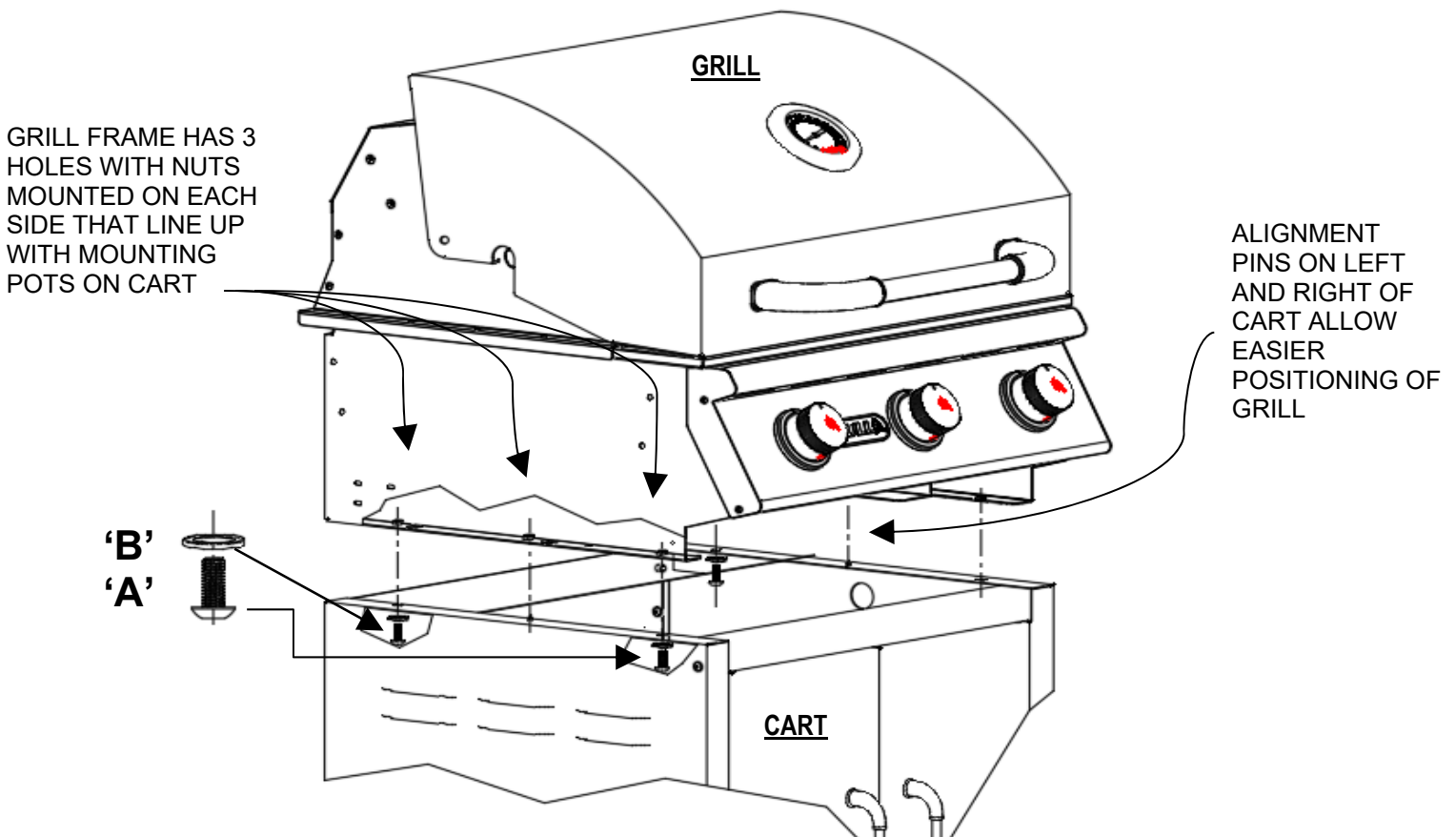



CART ASSEMBLY INSTRUCTIONS (CONTINUED)

Installing the Shelves to the Grill Head

The shelves and handles are already put together. You'll need the following to complete the shelf install:

- Both shelves that came with your cart
- 8 of fastener 'A' M5 x 12mm Long Hex Drive Button Head Screw 'A'
- 8 of washer 'B'
- Allen Wrench 'F'

Per illustrations below, attach the shelves to grill where shown. The grill has threaded inserts to hold the shelf fasteners.

NOTE:

These shelves are not intended to lift the grill.

To prevent damage to the cart do not attempt to use the shelves as way to lift the grill.

This side view below shows the location of the 4 mounting holes used to mount the shelves on each side of the grill.

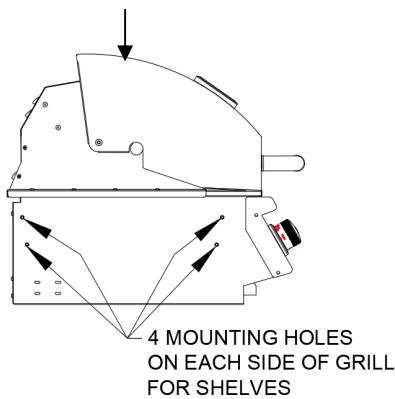

The view below shows the underside of a shelf and how the fasteners are used to mount the shelf to the grill.

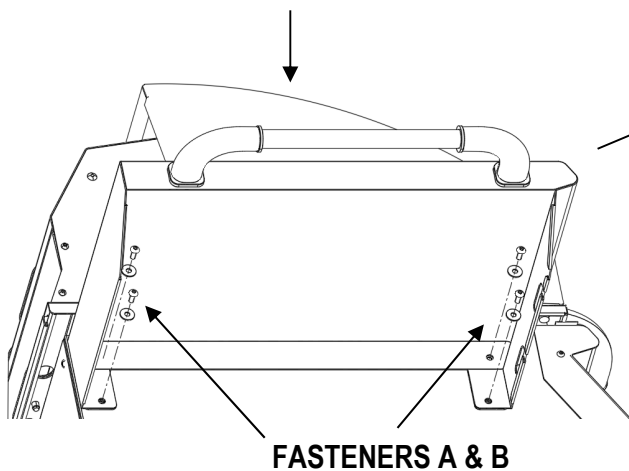

Use Allen Wrench 'F' and Fasteners 'A' and 'B' to attach the shelves. Note, Initially, all the fasteners should only be 'finger tight'. Doing this makes assembly easier and reducing the chance of cross threading the screws. Failure to do so may cause irreparable damage to the assembly. Use Allen wrench 'F' to tighten down the fasteners, if using a torque wrench the suggested setting is 4.35 ft lbs./ 5 Nm.

Grill shown with shelves installed.

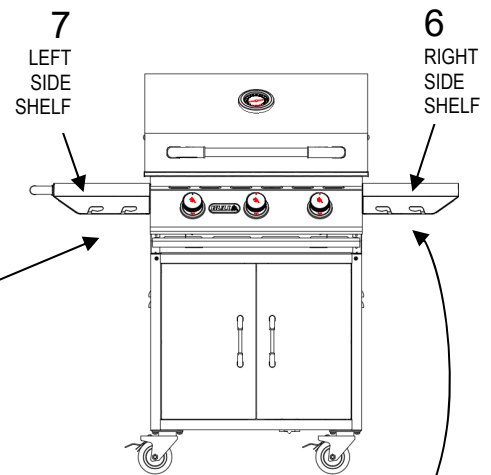

Note: Shelf notches used to hang cooking face equipment are to face the front of the grill.



Great job! Your grill cart assembly is now complete, and you can return the items you removed from the grill. Before using, please keep reading to understand all safety instructions in this manual and the manual included with your Grill before use.



⚠ LIQUID PROPANE (LP) SAFETY GUIDELINES ⚠

Your Propane gas grill is designed to operate on propane gas ONLY, at a pressure regulated at 11" water column (wc.) or 27.4 mbar when equipped with the correct propane orifices on the valves and a propane regulator on the supply line.

It is required that you only use an LP gas cylinder measuring 12 inches in diameter X 18 inches tall with a maximum capacity of 20 lb. In the United States, the LP gas cylinder must be constructed and marked in accordance with specifications of the US Department of Transportation for Propane Gas Cylinders.

- 1) Always keep LP gas cylinder securely fastened in an upright position.
- 2) Never connect an unregulated LP gas cylinder to the grill.
- 3) Do not subject LP gas cylinders to excessive heat.
- 4) Do not fill LP gas cylinder beyond 80% full.

CAUTION: NEVER STORE LP GAS CYLINDERS INSIDE A BUILDING, GARAGE OR IN THE VICINITY OF ANY GAS-BURNING APPLIANCE.

DANGER! IF YOU SMELL GAS, FOLLOW THE GUIDELINES BELOW:

- 1) Visually check burner flame status, and pilot burner flame if provided.
- 2) NEVER test for gas leaks with a lighted match or open flame.
- 3) Shut off gas source to the appliance.
- 4) Extinguish any open flame.
- 5) Open grill lid to release any accumulation of fumes.
- 6) If gas odor persists, immediately contact your gas supplier or your fire department.

CHECKING FOR GAS LEAKS

NEVER TEST FOR GAS LEAKS WHILE THE GRILL IS LIT!

It is a must that you use the steps below to check for leaks on LP Gas Grills prior to first use, start of a new BBQ season and whenever the gas cylinder is changed on LP Gas Grills.

- 1) Turn off heat control valve(s), and then turn on gas at source.
- 2) Make a soap solution by mixing one-part liquid detergent and one-part water.
- 3) Apply the soap solution to all gas connections: If air bubbles appear in the soap solution it means the connections are not properly sealed and need to be tightened or repaired as needed.
- 4) If you have a gas leak that you cannot repair, turn off the gas at the source, disconnect the fuel line from the grill and immediately call your grill dealer and gas supplier for professional assistance.

WARNING: If these guidelines are not followed, fire causing severe injury or death may occur.



LIQUID PROPANE (LP) 'TANK' CYLINDER INSTALL AND CONNECTION INSTRUCTIONS

LP Tank Install to Grill Cart Instructions:

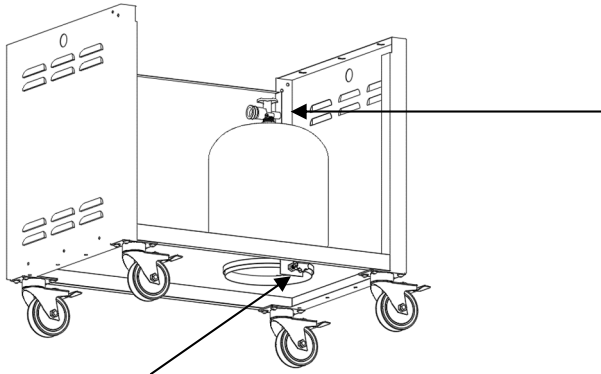

Your Cart uses a retainer to secure your tank in place.

- 1) Remove the cover for the hole that holds the tank (save the cover for future use)
- 2) Turn the retainer knob counterclockwise to make sure the retainer end is outside the opening where the tank will sit.
- 3) Place tank in cart opening with the with the tank cylinder valve is facing to the right as shown.
- 4) Your Grill Cart secures the LP Tank with a retainer you will need to tighten enough to lightly press on the Tank.

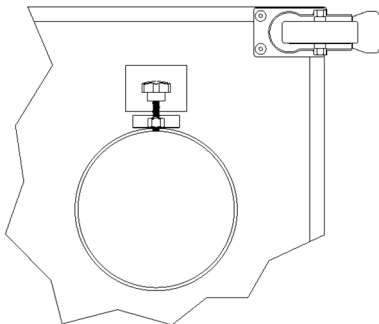

- WARNING!**
- 1) Do not store spare LP gas cylinders under or near this appliance.
 - 2) Do not fill LP gas cylinder beyond 80% full.

! If warning notice 1 & 2 are not followed exactly as written a fire causing death or serious injury may occur

CAUTION: Do not change gas tanks near any source of ignition.

- 3) LP Gas Tank must be identified in accordance with The Specifications for LP Gas Cylinders, Spheres and Tubes for Transportation of Dangerous Goods and Commission, CAN/CSA- B339, as applicable.
- 4) LP Gas Tank connection device is compatible with outdoor cooking appliances.
- 5) LP Gas Tank has appropriate vapor withdrawal.
- 6) LP Gas Tank must have a listed overfilling prevention device.
See Illustration below for instructions 7-11
- 7) LP Gas Tank must include a collar to protect the cylinder valve.
- 8) LP Gas Tank uses a type 1 tank valve that must be firmly secured in an upright position.
- 9) LP Gas pressure regulator and 31" inch hose assembly (Bull Part # 16589) are supplied and must be used without alteration and should only be used on your Bull Grill Cart.
- 10) If the hose assembly needs replacement, refer to illustration below or your Bull Grill manual for part number info.
- 11) To connect, turn the black coupling nut of the hose and regulator assembly in a clockwise direction (see illustration below) until completely threaded onto the cylinder valve before turning gas supply on. To remove turn the black coupling nut of the hose and regulator assembly in a counter-clockwise direction.

UNITED STATES LP TANK CONNECTION

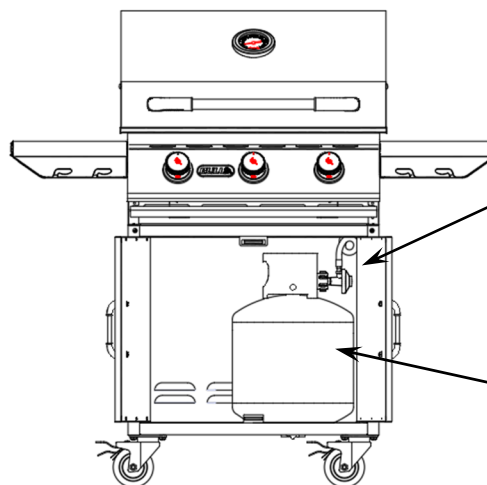
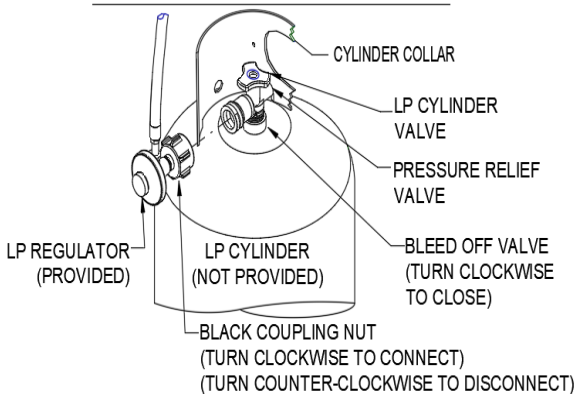

SST FLEX HOSE PART # 16598 AND FITTING PART # 47006 FOR CONNECTION GRILL SUPPLIED BY BULL
 LP REGULATOR WITH SST BRAIDED HOSE LINE PART # 16589 WITH ATTACHED LP HOSE CLIP PART # 48094 SUPPLIED BY BULL

LP TANK CYLINDER (NOT SUPPLIED BY BULL)



LOCATION AND VENTILATION GUIDELINES

⚠ (PLEASE READ THESE INSTRUCTIONS BEFORE USING YOUR CART) ⚠

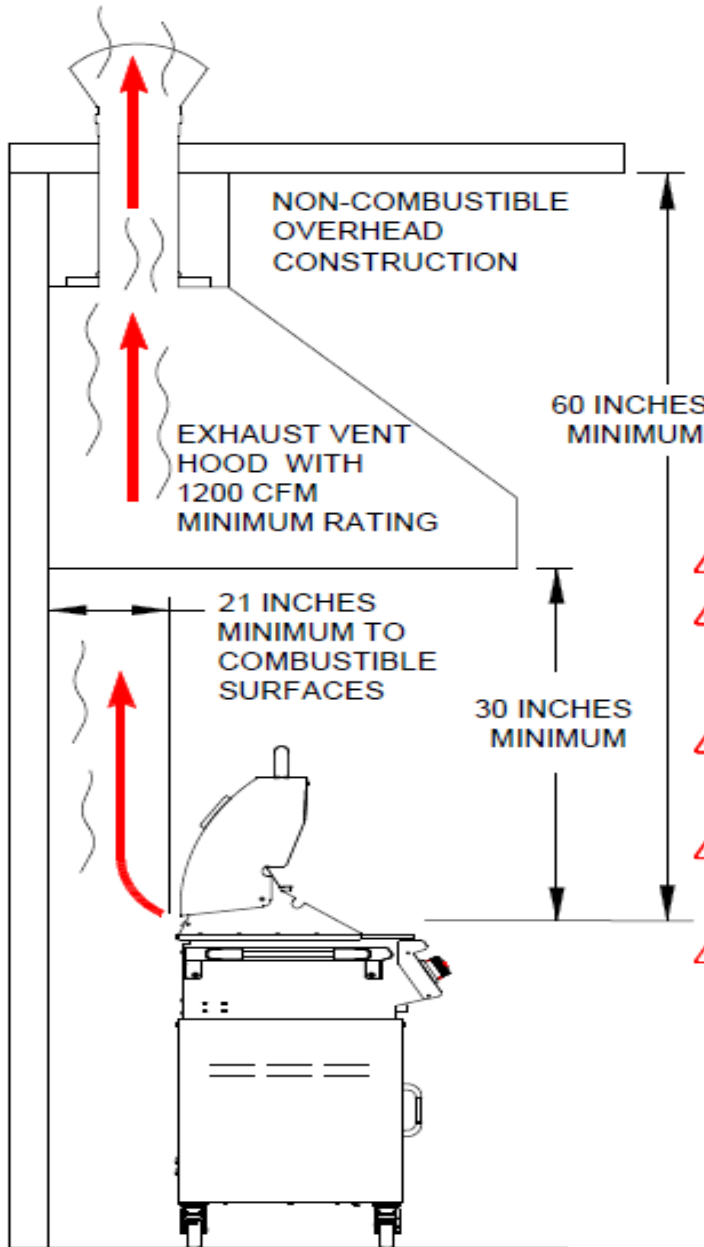

⚠ IMPORTANT!

DO **NOT** PLACE OR INSTALL YOUR CART GRILL IN AN

- 1) ENCLOSED AREA
- 2) BREEZEWAY
- 3) SCREENED-IN PATIO
- 4) INSIDE A BUILDING

⚠ IMPORTANT!

IF GRILL LOCATION HAS OVERHEAD CONSTRUCTION PRESENT YOU **MUST** FOLLOW THESE INSTRUCTIONS :

- ⚠ 1) DO NOT INSTALL GRILL UNDER A COMBUSTIBLE COVER.
- ⚠ 2) A MINIMUM HEIGHT SEPARATION OF 60 INCHES FROM COOKING SURFACE TO ANY OVERHEAD NON-CONSTRUCTION **MUST** BE MET UNLESS OTHERWISE STATED BY LOCAL BUILDING AND FIRE CODE REQUIREMENTS.
- ⚠ 3) A VENTILATION HOOD **MUST** BE INSTALLED ABOVE THE COOKING SURFACE WITH A MINIMUM 30 INCHES OF CLEARANCE BETWEEN VENTILATION HOOD AND COOKING SURFACE
- ⚠ 4) VENTILATION HOOD **MUST** BE LARGER THAN THE COOKING SURFACE WITH A MINIMUM OF 3 INCHES OF OVERLAP ON EACH SIDE OF COOKING SURFACE.
- ⚠ 5) VENTILATION HOOD **MUST** BE RATED WITH A MINIMUM OF 1200 CFM (CUBIC FEET PER MINUTE) FOR PROPER APPLICATION.



(LP) GRILL OPERATING INSTRUCTIONS

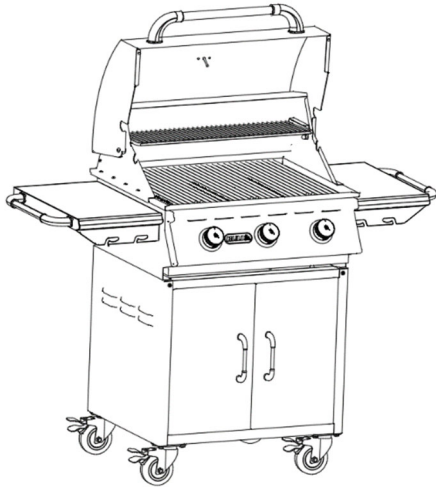

! SAFETY INSTRUCTIONS !



BEWARE OF CLOGGED BURNERS DUE TO SPIDER WEBS

**CAUTION: BURNERS MUST BE INSPECTED AND CLEANED
BEFORE FIRST USE**

Spiders and small insects occasionally spin webs or make nests in the burners during warehousing, transit and/or after long periods of non- use. These webs can lead to a gas flow obstruction, which could result in a fire in and around the burner venturi tubes. This type of fire is known as "FLASH-BACK" and can cause serious damage to your grill and create an unsafe operating condition for the user. Although an obstructed burner tube is not the only cause of "FLASH BACK" it is the most common cause, and frequent inspection and cleaning of the burners is necessary.

WARNING! FOR YOUR SAFETY FOLLOW THE GUIDELINES BELOW:

- ! PLEASE NOTE: YOUR GAS GRILL CART IS ONLY FOR OUTDOOR USE**
- ! PROTECT CHILDREN: DO NOT ALLOW CHILDREN TO OPERATE GRILL.** Keep them away from the grill during use, and until the grill has cooled completely.
- ! DO NOT use your gas grill in enclosed areas, i.e., garages, porches, breezeways, sheds.**
- ! DO NOT place the grill under or on top of any surface that will burn.**
- ! DO NOT allow obstruction to the flow of combustion and ventilation air around the grill housing.**
- ! Grill clearance from the back and side of any combustible surface must be at least 21 inches.**
- ! DO NOT store or use gasoline, or other liquids emitting flammable vapors in the vicinity of grill or any other appliances.**
- ! DO NOT store empty or full spare LP gas cylinders and/or chemicals under or near grill or any other appliances.**
- ! Keep the fuel hose and electrical cord away from hot surfaces and dripping grease.**
- ! Check and clean burner venturi tubes for insects and debris. A clogged tube can lead to a fire beneath the grill. Keep the vent openings of the cylinder enclosure free and clear from debris.**
- ! Clean outdoor cooking gas appliance with recommended cleaning agents.**
- ! NEVER light grill with lid closed or before checking to ensure burner tubes are fully seated over gas valve orifices.**
- ! NEVER lean over cooking surface while lighting grill. Use barbecue tools with wood handles and good quality insulated oven mitts when operating grill.**
- ! Visually inspect the LP hose prior to each use for cuts, cracks, excessive wear, or other damage and replace if necessary.**

WARNING NEVER cover slots, holes or passage in the grill bottom or cover an entire cooking grate with material, i.e., aluminum foil. Doing so blocks air flow through the oven and may cause carbon monoxide poisoning. Aluminum foil linings may trap heat causing a fire hazard.

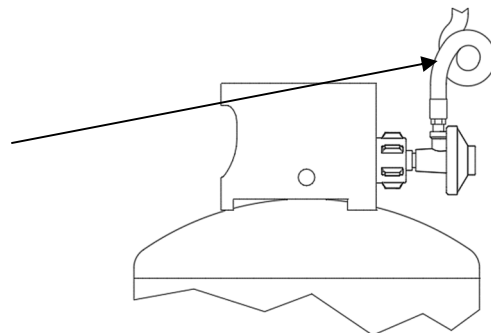

NEVER PLACE UTENSILS ON TOP GRILL LID



CART CLEANING AND MAINTENANCE

First set the swivel casters wheels in the **locked position** to prevent the cart from moving and causing injury.



Next: Follow these steps for cleaning your grill cart:

- Make sure the grill head and cart are cool to the touch.
- Wipe down the cart with stainless steel cleaner.

STAINLESS STEEL CLEANING AND MAINTENANCE

Stainless steel is a corrosion resistant chromium/nickel alloy steel that is both durable as well as strong with an outstanding luster. The goal of your cleaning and maintenance routine should be to keep the stainless steel's protective chromium oxide layer intact. This is what prevents corrosion. Contrary to popular belief, stainless steel is NOT rustproof, especially in the environment of a swimming pool. Chlorine, bromine, some fertilizers, and other elements are extremely caustic chemicals for stainless steel. These chemicals combined with heat and humidity can increase the corrosiveness of these chemicals. Regular cleaning is the best way to prevent corrosion and add years of enjoyment to your Bull stainless steel products.



LIQUID PROPANE (LP) SAFETY GUIDELINES

WHEN OUTDOOR COOKING GAS APPLIANCE IS NOT IN USE:

- 1) The LP gas must be turned off at the supply cylinder.
- 2) Do not store spare LP gas cylinders under or near this appliance.
- 3) Spare LP gas cylinders must be stored outside in an adequately ventilated area that is isolated from the grill.
- 4) Spare LP gas cylinders must be kept out of the reach of children and must not be stored inside buildings or any other enclosed areas.
- 5) Storage of an outdoor cooking gas appliance indoors is permissible only if the cylinder is disconnected and removed from the outdoor cooking gas appliance.
- 6) The LP gas cylinder must be equipped with an arrangement for vapor withdrawal.
- 7) The LP gas cylinder must include a collar to protect the cylinder valve.
- 8) Place dust cap on cylinder valve outlet whenever the cylinder is not in use. Only install the type of dust cap on the cylinder valve outlet that is provided with the cylinder valve. Other types of caps or plugs may result in leakage of propane.

WARNING: If these guidelines are not followed, fire causing serious injury or death may occur.



Warranty Policy

LIMITED WARRANTY ON BULL OUTDOOR PRODUCTS, INC., PRODUCTS

THIS LIMITED WARRANTY GIVES YOU SPECIFIC LEGAL RIGHTS. YOU MAY ALSO HAVE OTHER RIGHTS, WHICH VARY FROM STATE TO STATE.

THIS LIMITED WARRANTY CAN ALSO BE FOUND ON OUR WEB SITE AT:

<https://www.bullbbq.com/support-warranty> (United States Customers)

<https://bullbbq.eu/customer-care/#warranty-registration-form> (International Customers)

AND IN THE OWNER'S/INSTALLATION MANUAL THAT WE PROVIDE WITH OUR PRODUCT.

THIS LIMITED WARRANTY IS SUBJECT TO THE EXCLUSIONS, CONDITIONS AND LIMITATIONS SET FORTH BELOW.

ANY IMPLIED WARRANTIES IMPOSED BY LAW, INCLUDING WITHOUT LIMITATION THE IMPLIED WARRANTIES OF MERCHANTABILITY AND FITNESS FOR A PARTICULAR PURPOSE, ARE LIMITED IN DURATION TO THE DURATION OF THIS EXPRESS LIMITED WARRANTY. SOME STATES DO NOT ALLOW LIMITATIONS ON HOW LONG AN IMPLIED WARRANTY LASTS, SO THE ABOVE LIMITATION MAY NOT APPLY TO YOU.

WHO MAY USE THIS WARRANTY?

BULL OUTDOOR PRODUCTS, INC. located at address 1011 East Pine St. Lodi, CA. 95240 ("we") extend this limited warranty only to the consumer who originally purchased the product ("you") at the original site of delivery or installation. It does not extend to any subsequent owner or other transferee of the product. It does not apply to products installed in any rental, commercial or non-residential application. Examples of excluded applications include, but are not limited to day care centers, schools, bed and breakfast centers, churches, private clubs, fire stations, club houses, common areas in multi-family dwellings, restaurants, hotels, nursing homes, food service locations and institutional food service locations.

WHAT DOES THIS WARRANTY COVER?

This limited warranty covers defects in materials and workmanship of the product and product components identified below for the Warranty Periods defined below.

WHAT IS THE PERIOD OF COVERAGE?

This limited warranty starts on the date of your purchase and lasts for the time period or time periods specified above (the "**Warranty Period**"). The Warranty Period is not extended if we repair or replace the product. We may change the availability of this limited warranty at our discretion, but any changes will not be retroactive.



Warranty Policy (Continued)

Grill Warranty Periods

The following parts are covered for **one year** on all our current gas grill models:

The lid, control panel, grease tray, bezels, knobs, temperature gauge, valves, regulator, flex tubes, rotisserie burner, transformer, and all components of the lighting system.

The following parts are covered for **three years** on all our current gas grill models:

The manifold, handle end caps, flame tamers, heat shields, and warming rack.

The following parts are covered for **lifetime** on all our current gas grill models:

Insert assembly and the grates.

The warranty period for the grill burners vary by type:

Cast stainless steel burners - **lifetime**,
Welded burners – **5 years**, and
Porcelain coated burners – **3 years**.

The warranty period for the charcoal grill is **one year** on all parts, except for the insert assembly, which is covered for **5 years**.

The Bel Air grill included a **one-year** warranty on all parts.

- **Component Warranty Periods**

All of the parts for our components/grill carts/refrigerators/kegerators/drawers/doors are covered for **one year** with these exceptions:

Power Burner

- The insert/grates are **lifetime** covered parts.
- The manifold/burner are covered for **3 years**.

Searing Station/Slide in Double Sideburner

- The grates are covered for **lifetime**,
- the insert for **5 years**, and
- the manifold for **3 years**.

Single Sideburner

- The grates are covered for **5 years** and
- the burner for **3 years**.

Sidekick

- The burner is covered for **3 years**.



Warranty Policy (Continued)

- **Pizza Ovens/Islands/Fire Features Warranty Periods**

All of the parts and construction materials are covered for *one year*.

Grill Accessories and Grill Covers do not include a warranty period.

WHAT DOES THIS WARRANTY NOT COVER?

This limited warranty does not cover any damage due to: (a) transportation; (b) storage; (c) improper installation or use; (d) use on improper fuel/gas supply; (e) failure to follow the product instructions or to perform any preventive maintenance; (f) modifications; (g) unauthorized repair; (h) normal wear and tear; or (i) external causes such as accidents, abuse, or other actions or events beyond our reasonable control.

WHAT ARE YOUR REMEDIES UNDER THIS WARRANTY?

With respect to any defective product claim made during the Warranty Period, we will, in our sole discretion, either: repair or replace such product (or the defective part) free of charge or (b) refund the purchase price of such product. We will not pay for shipping charges for repaired or replacement parts, or for any labor or labor related charges. We will not pay for any accessory products or ancillary products purchased by you for use in connection with the product.

HOW DO YOU OBTAIN WARRANTY SERVICE?

To obtain warranty service, you must submit a warranty claim online through the Bullbbq.com website during the Warranty Period. Warranty claims will not be accepted via email, fax or phone.

LIMITATION OF LIABILITY

THE REMEDIES DESCRIBED ABOVE ARE YOUR SOLE AND EXCLUSIVE REMEDIES AND OUR ENTIRE LIABILITY FOR ANY BREACH OF THIS LIMITED WARRANTY. OUR LIABILITY SHALL UNDER NO CIRCUMSTANCES EXCEED THE ACTUAL AMOUNT PAID BY YOU FOR THE DEFECTIVE PRODUCT, NOR SHALL WE UNDER ANY CIRCUMSTANCES BE LIABLE FOR ANY CONSEQUENTIAL, INCIDENTAL, SPECIAL OR PUNITIVE DAMAGES OR LOSSES, WHETHER DIRECT OR INDIRECT.

SOME STATES DO NOT ALLOW THE EXCLUSION OR LIMITATION OF INCIDENTAL OR CONSEQUENTIAL DAMAGES, SO THE ABOVE LIMITATION OR EXCLUSION MAY NOT APPLY TO YOU.

Revised 10-15-2020 APR