

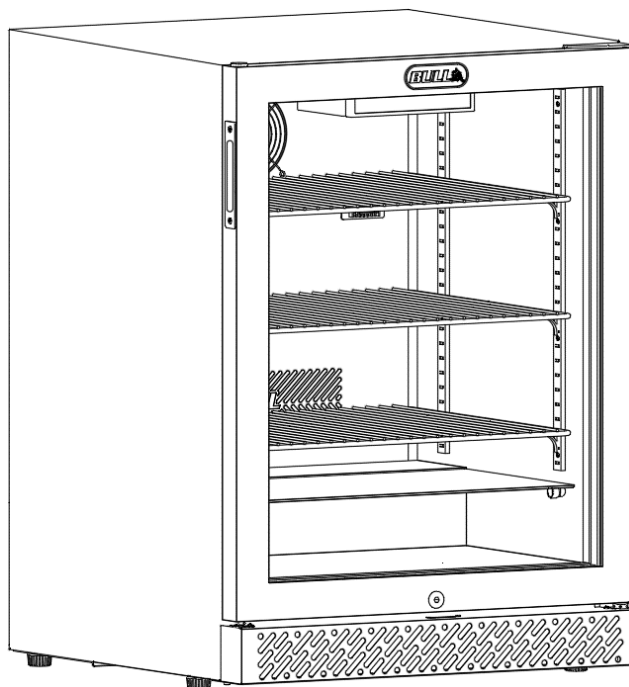

**PREMIUM OUTDOOR  
RATED REFRIGERATOR SERIES II  
WITH GLASS DOOR  
OWNER'S MANUAL  
ITEM NO.13100**



**READ AND RETAIN THIS OWNER'S MANUAL FOR FUTURE REFERENCE.**

**BEFORE USING**

**PLEASE READ AND FOLLOW ALL THE SAFETY RULES AND OPERATING INSTRUCTIONS.**

**PLEASE NOTE**, YOUR GLASS DOOR REFRIGERATOR IS BUILT TO THE HIGHEST STANDARDS, BUT EXCESSIVE HEAT AND SUNLIGHT WILL AFFECT OPERATING EFFICIENCY AND PRODUCT LIFESPAN. THESE PRECAUTIONS SHOULD **ALWAYS** BE CONSIDERED REGARDING WHERE IT IS OPERATED FOR BEST RESULTS:

- 1) **AVOID** INSTALLING REFRIGERATOR IN A LOCATION ALLOWING EXPOSURE TO DIRECT SUNLIGHT AND OR EXCESSIVE HEAT. IF UNAVOIDABLE A SOLID DOOR REPLACEMENT IS AVAILABLE THRU BULL.
- 2) **DO NOT** INSTALL IN LOCATION THAT COULD RESULT IN GLASS DOOR BEING STRUCK, I.E. (PLAY AREA, ETC.)

**READ AND RETAIN THIS OWNER'S MANUAL FOR FUTURE REFERENCE.**



USA EDITION



<b>TABLE OF CONTENTS</b>		<b>PAGE NO.</b>
<b>APPLIANCE SAFETY</b>		<b>3-4</b>
<b>LOCATION OF PARTS</b>		<b>5</b>
<b>INSTALLATION INSTRUCTIONS</b>		
DO THIS BEFORE USING YOUR APPLIANCE		<b>5</b>
INSTALLATION (PREPARATION, GENERAL GUIDELINES)		<b>5</b>
ELECTRICAL (EXTENSION CORD WARNING)		<b>6</b>
REVERSING THE DOOR SWING		<b>6-9</b>
<b>OPERATING YOUR REFRIGERATOR</b>		
CONTROL PANEL	10 ↑ ↓ 10	
INTERIOR LIGHT		
DEFROSTING		
TEMPERATURE ALARM/ DOOR ALARM		
DOOR LOCK		
PREPARATION FOR USE		
SHELVES		
<b>CARE AND MAINTENANCE</b>		
CLEANING	<b>11</b>	
POWER FAILURE	↑ ↓	
VACATION TIME		
MOVING YOUR REFRIGERATOR		
ENERGY SAVING TIPS		
APPLIANCE DISPOSAL	<b>11</b>	
<b>TROUBLE SHOOTING</b>		<b>12</b>
<b>PRODUCT REGISTRATION</b>		
<b>ORDERING REPLACEMENT PARTS</b>		<b>13</b>
<b>REPLACEMENT PARTS LIST</b>		
<b>EXPLODED VIEW FOR PARTS LIST</b>		<b>14</b>
<b>WARRANTY POLICY</b>		<b>15-17</b>

v2024.07.23

 **WARNING:** This product can expose you to chemicals including Nickel (Metallic) which is known to the State of California to cause cancer.

For more information go to [www.P65Warnings.ca.gov](http://www.P65Warnings.ca.gov)

Note: Nickel is a component in all stainless steel and some other metal components.



## APPLIANCE SAFETY

### Your safety and safety of others is very important.

We have provided many important safety messages in this manual and on your appliance. Always read and obey all safety messages.



This is the Safety Alert Symbol. The symbol alerts you to potential hazards that kill or injure you or others. All safety messages will follow the Safety Alert Symbol or be identified by either the DANGER or WARNING label that is shown and defined below.



**DANGER** means that failure to heed this safety statement may result in severe personal injury or death.



**WARNING** means that failure to heed this safety statement may result in extensive product damage, serious personal injury, or death.

All safety messages will alert you about the potential hazard, tell you how to reduce the chance of injury, and let you know what can happen if the instructions are not followed.

---

## IMPORTANT SAFEGUARDS



Before the appliance is used, it must be properly positioned and installed as described in this manual, so read the manual carefully.

To reduce the risk of fire electrical shock or injury when using this appliance, follow basic precautions including the following:

- 1) Plug into a grounded outlet, do not remove grounding prong, do not use an adapter, and do not use an extension cord.
- 2) Replace all panels before operating.
- 3) It is recommended that a separate circuit serving only your appliance be provided. Use receptacles that cannot be turned off by a switch or pull chain.
- 4) Never clean appliance parts with flammable fluids. These fumes can create a fire hazard or explosion. And do not store or use gasoline or other flammable vapours and liquids in the vicinity of this or any other appliance. The fumes can create a fire hazard or explosion.
- 5) Do not connect or disconnect the electric plug when your hands are wet.
- 6) Unplug the appliance or disconnect power before cleaning or servicing. Failure to do so can result in electrical shock or death.
- 7) Do not attempt to repair or replace any part of your appliance unless it is specifically recommended in this manual. All other services should be referred to a qualified technician.



**IMPORTANT SAFEGUARDS**

**⚠ WARNING**

FOLLOW WARNING CALLOUTS BELOW ONLY WHEN APPLICABLE TO YOUR MODEL.

- Use two or more people to move and install this appliance. Failure to do so can result in back or other injury.
- To ensure proper ventilation of this appliance, the front of the unit must be completely unobstructed.
- Choose a well-ventilated area with temperatures above 50°F (10°C) and below 109.4°F (43°C).
- The appliance should not be located next to ovens, grills or other sources of high heat.
- The appliance must be installed with all electrical, water and drain connections in accordance with state and local codes. A standard electrical supply, properly grounded in accordance with the National Electric Code and local codes and ordinances.

PRODUCT VOLTAGE	HERTZ
110V(US)	60HZ
220V	50HZ

Do not kink or pinch the power supply cord of the appliance.

The size of the fuse (or circuit breaker) should be:

PRODUCT VOLTAGE	AMPERE
110V(US)	1.3A
220V	1.0A

- It is important that the appliance be levelled to work properly. You may need to make several adjustments to level it.
- All installations must be in accordance with local plumbing code requirements. Make certain that the pipes are not pinched, kinked, or damaged during installation. Check for leaks after connection.
- Never allow children to operate, play with or crawl inside the appliance.
- Do not use solvent-based cleaning agents or abrasives on the interior. These cleaners may damage or discolor the interior.
- Use this appliance only for its intended purpose as described in this *Instruction Manual*.
- Keep fingers out of the "pinch point" areas. Clearances between the door and cabinet are small by necessity.
- Be careful closing door when children are in the area.

**⚠ DANGER ⚠**

***Risk of child entrapment!***

Child entrapment and suffocation are not problems of the past. Junked or abandoned appliances are still dangerous, even if they will "just sit for a few days".

***Before discarding your old refrigerator:***

***Take off the doors.***

*Leave the shelves in place so that children may not easily climb inside.*

**-SAVE THESE INSTRUCTIONS-**



## LOCATION OF PARTS

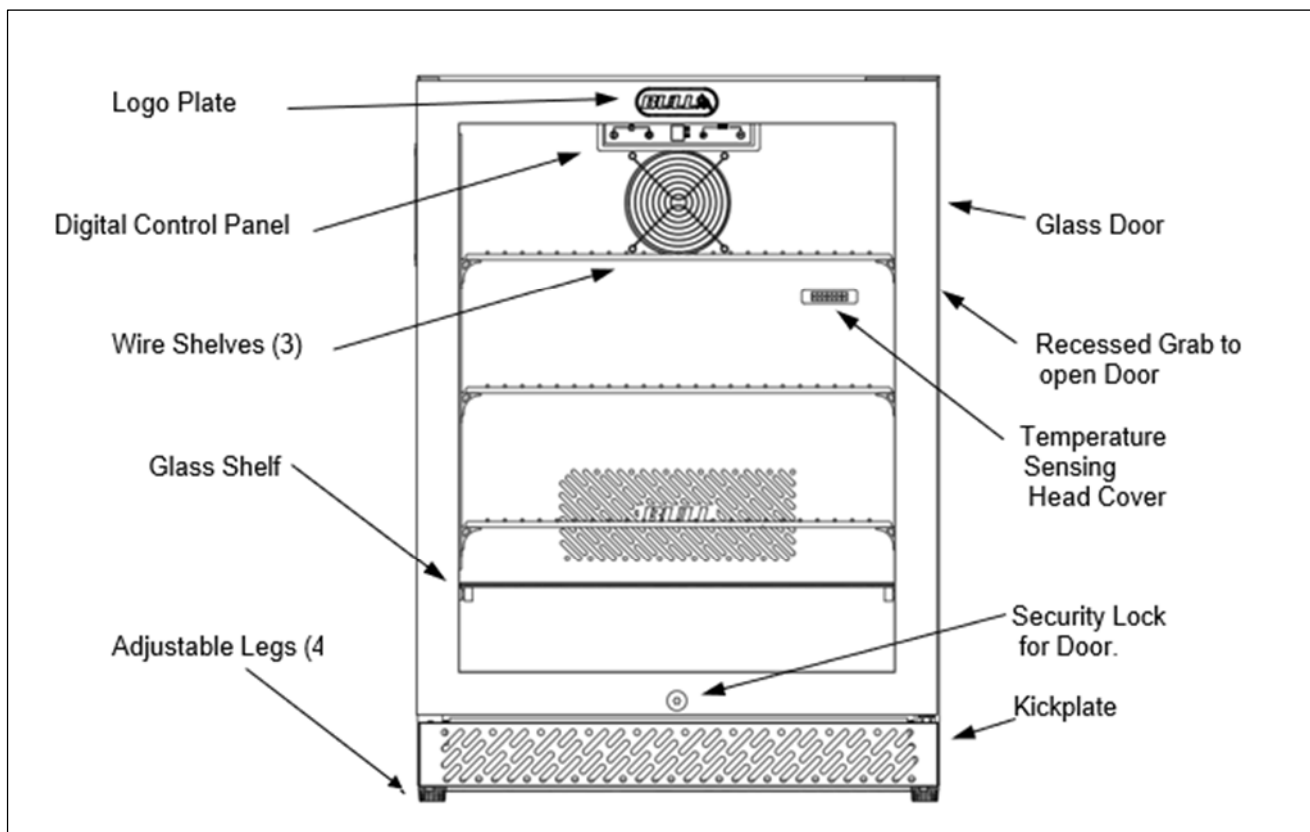

### **BEFORE USING YOUR APPLIANCE**

- 1) Remove the exterior and interior packing.
- 2) Before connecting the appliance to the power source, let it stand upright for approximately 24 hours. This will reduce the possibility of a malfunction in the cooling system from handling during transportation.
- 3) Clean the interior surface with lukewarm water using a soft cloth.

## INSTALLATION INSTRUCTIONS

### **INSTALLATION OF YOUR APPLIANCE**

- 1) Please consider exposure to heat and sunlight when selecting the location for your refrigerator.
- 2) The appliance is designed for built-in recessed or free-standing installation.
- 3) Note: may be used this appliance for the storage of medicine and other medical products.
- 4) Place your appliance on a floor that is strong enough to support it when it is fully loaded. To level the unit, adjust the front levelling legs.

Take care that the air vent at the front of the appliance is never covered or blocked in any way.

**Note:** It is recommended that you do not install the appliance near an oven, radiator or other heating source as these heat sources may increase your appliances electrical consumption. Don't install in a location where the temperature will fall below 50°F (10°C) For best performance, do not install the appliance behind a cabinet door or block the base grill. Avoid locating the unit in moist areas. Plug the appliance into an exclusive properly grounded wall outside.



## ELECTRICAL CONNECTION

### **⚠ WARNING**

Improper use of the grounded plug can result in the risk of electrical shock. If the power cord is damaged, have it replaced by a qualified electrician or authorized service center.  
Plug the appliance into an exclusive properly grounded wall outside.

For personal safety, this appliance must be properly grounded. Any questions concerning power and/or grounding should be directed toward a qualified electrician or authorized service center.

This appliance requires a standard electrical outlet. Have the wall outlet and circuit checked by a qualified electrician to make sure the outlet is properly grounded.

To prevent electrical accidental injury. The cord should be secured behind the appliance and not left exposed or dangling.

The appliance should always be plugged into its own individual electrical outlet which has a voltage rating that matches the rating on the appliance. This provides the best performance and prevents overloading house wiring circuits that could cause a fire hazard from overheating. Never unplug the appliance by pulling on the power cord. Always grip the plug firmly and pull straight out from the receptacle. Repair or replace immediately all power cords that have become frayed or otherwise damaged. Do not use a cord that shows cracks or abrasion damage along its length or at either end.  
When moving the appliance, be careful not to damage the power cord.

### **EXTENSION CORD**

Because of potential safety hazards under certain conditions. It is strongly recommended that you do not use an extension cord with this appliance.

### **REVERSING THE DOOR SWING**

This door of this appliance has the capability of swinging opening from either the left or right side. It is shipped to you with the door opening on the left side.

### **⚠ DANGER ⚠**

(Before you start, un-plug power cord and empty contents)

Before reversing the door swing, please read pages 6-9 and carefully follow the reversing instructions. Skipping steps might result in expected personal injury. To prevent serious injury wear Eye and Hand Protection.

**(Appliance is shipped this way)**

**(Reversed door opening option)**

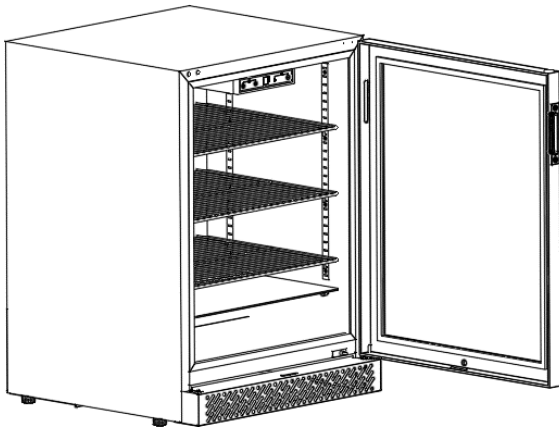

Door opens on Left Side with Right Hinge Swing

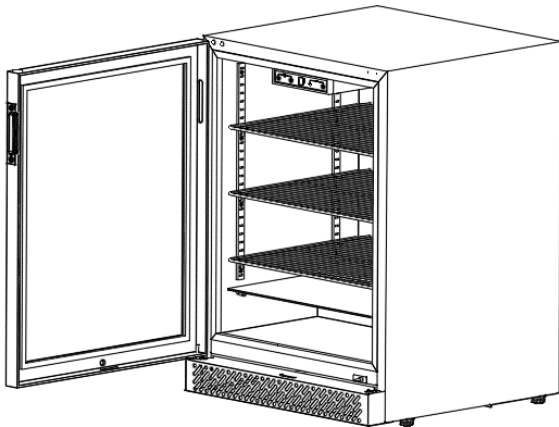

Door opens on Right Side with Left Hinge Swing

**CONTINUE TO NEXT PAGE FOR INSTRUCTIONS**



## **INSTRUCTIONS FOR REVERSING THE DOOR SWING**

### **STEP 1:**

Un-plug power cord and remove the 3 wire shelves and glass shelf.

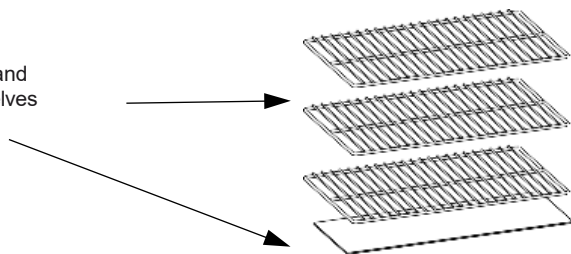

### **STEP 2:**

Remove the 2 screws holding the Kickplate as shown and put aside.

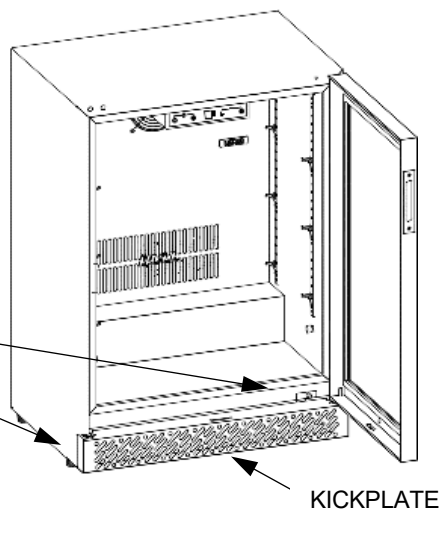
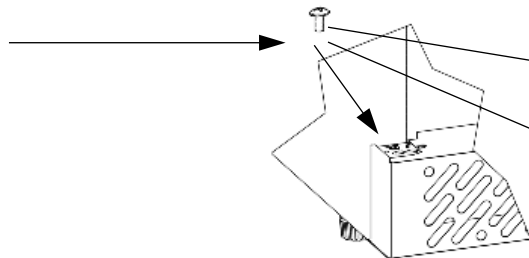

### **STEP 3:**

You'll need to place something on the ground such as sheets of cardboard to protect the back side of the refrigerator. Next, carefully rotate Refrigerator so backside is resting on ground as shown.

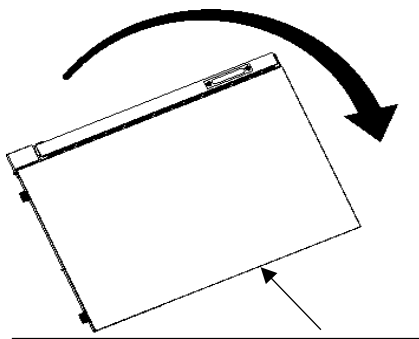

**BACKSIDE OF REFRIGERATOR**

### **STEP 4:**

Remove and retain the 2 screws on the bottom of the Kickplate. Remove and retain Kickplate

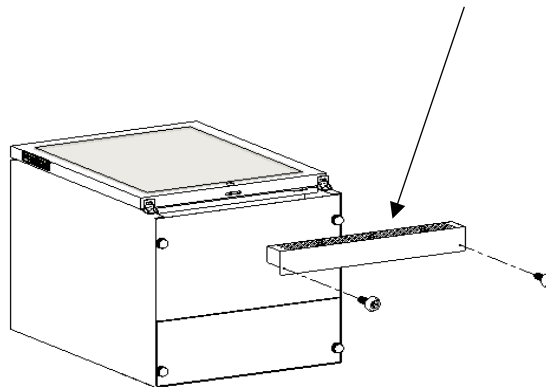

### **STEP 5:**

Remove retain the 2 screws holding the bottom hinge support bracket, during removal you'll notice the bracket is under tension that will release while removing the screws which is normal

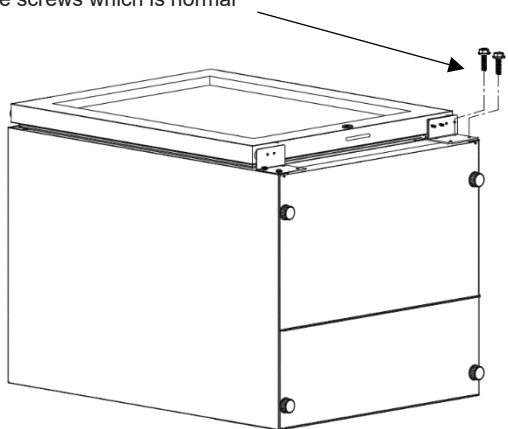

### **STEP 6:**

Slide the bottom hinge assembly out of the bottom of the door. Then slide the door off the upper pivot hinge.

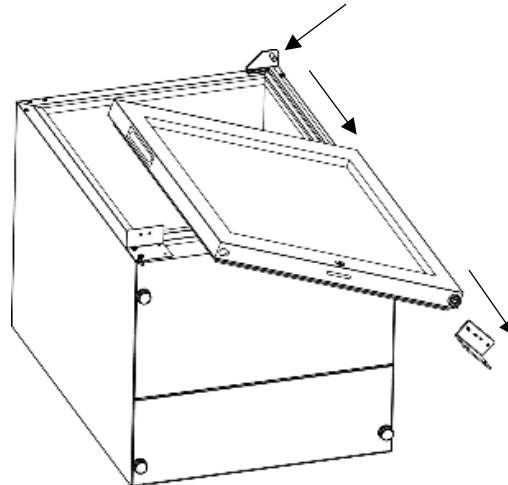

**CONTINUE ON TO NEXT PAGE**





# INSTRUCTIONS FOR REVERSING THE DOOR SWING (CONTINUED)

(Un-plug power cord while doing this)

## STEP 7:

Remove x3 decorative hole plugs (top Left)

Remove top right pivot hinge (x3 screws)

Remove bottom left angle bracket (x2 screws)

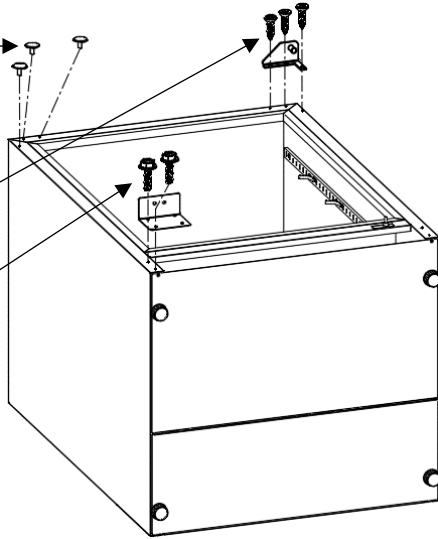

## STEP 8:

Install (x3 screws) top left hinge bracket (supplied in parts bag).

Push in x3 decorative hole plugs (top right).

Move the kickplate angle bracket from bottom left to bottom right (x2 screws)

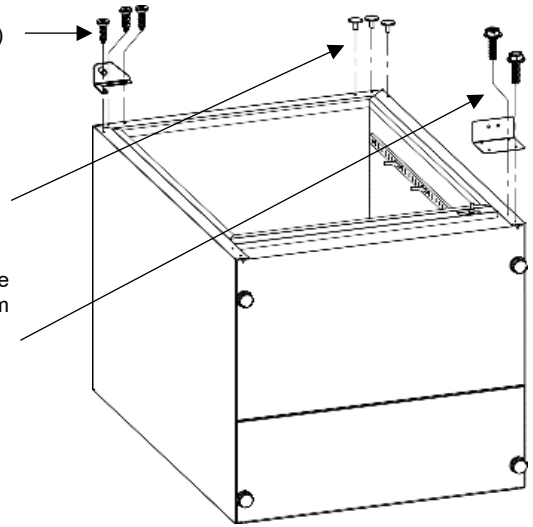

## STEP 9:

Remove the decorative plug from the top left of the door

Take the decorative plug from the top left of the door and install it into the top right of the door.

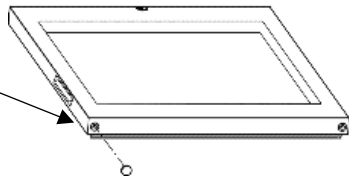
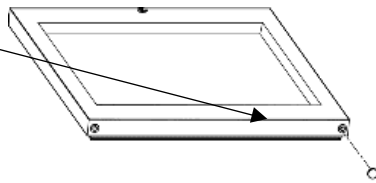

## STEP 10:

Remove the spring tension plug (off white plastic) and bearing from the bottom right of door.

Install the black spring tension plug (supplied in parts bag) to the bottom left of the door.

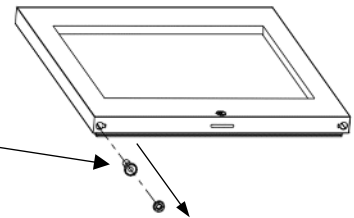
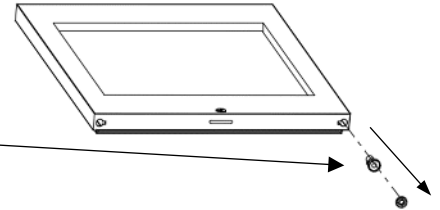

## STEP 11:

Slide the door up onto the top left pivot hinge and allow door to lay flat



## STEP 12:

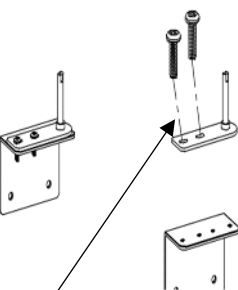

Take the angle bracket pivot assembly and remove the two screws

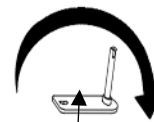

Rotate the spring tension rod bracket 180 degrees.

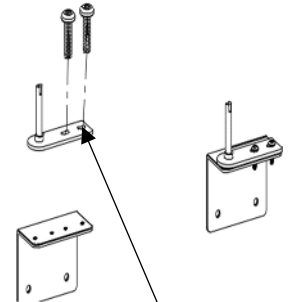

Screw the assembly back together to be a mirror image of

CONTINUE ON TO NEXT PAGE





## INSTRUCTIONS FOR REVERSING THE DOOR SWING (CONTINUED)

### **STEP 13:**

Insert the angle bracket pivot assembly into the spring tension plug (be sure the support bearings are still there).  
refrigerator with screws retained during Step 7  
When fully inserted and the spring is engaged, rotate the assembly 90 degrees clockwise and screw the bracket to the bottom left of the refrigerator.

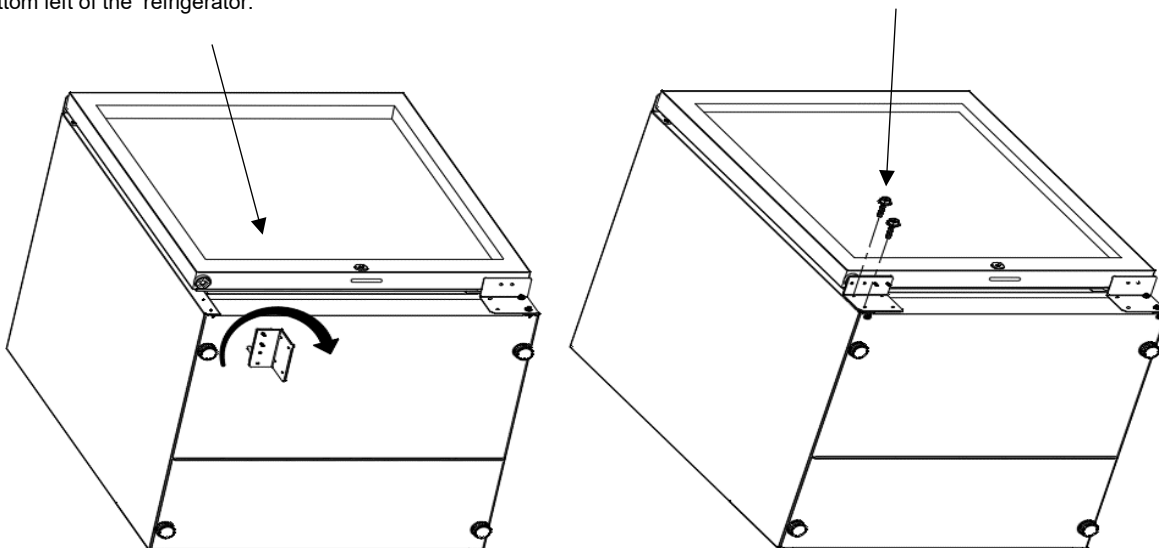

### **STEP 14:**

Slide Kickplate back on to the bottom and secure it with the two screws retained during Step 4.

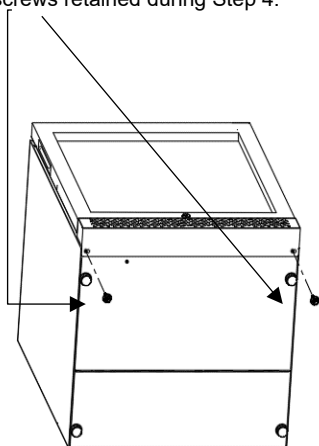

### **STEP 15:**

Rotate the Fridge back on its feet.

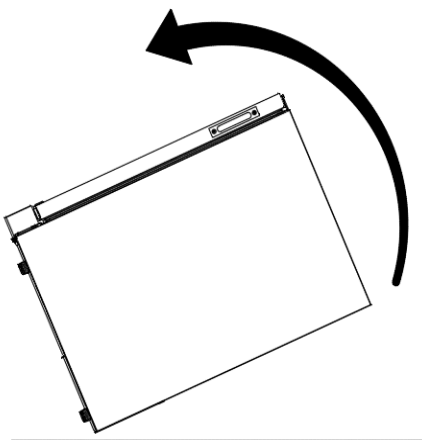

### **STEP 16:**

Complete installing the Kickplate with screws removed during Step 2.

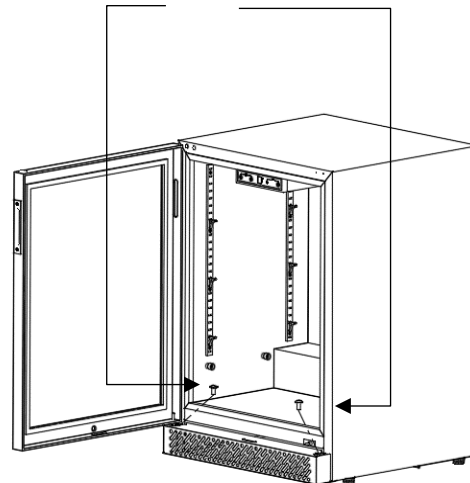

### **STEP 17:**

Test the swing of the door to be sure it closes on its own. Add the screw to bottom kickplate with the door open for access.  
Replace the shelves. Wait an hour before turning the refrigerator back on.

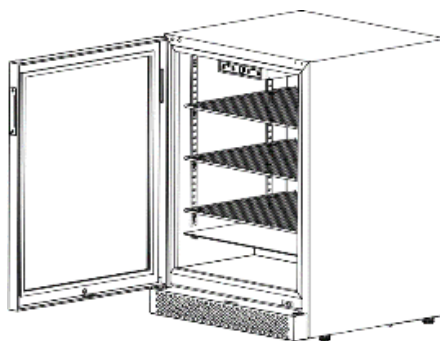



## OPERATING INSTRUCTIONS

It is recommended that you install the refrigerator in place where the ambient temperature is 50 °F and 109.4 °F (10°C – 43°C). If the ambient temperature is above or below recommended temperatures, the performance of the unit may be affected. For example, placing your refrigerator in extremely cold or hot conditions may cause interior temperatures to fluctuate. The operating temperature range may not be reached. The display for your refrigerator's Control Panel is shown below with numbers that correspond with list below to explain the operational controls.

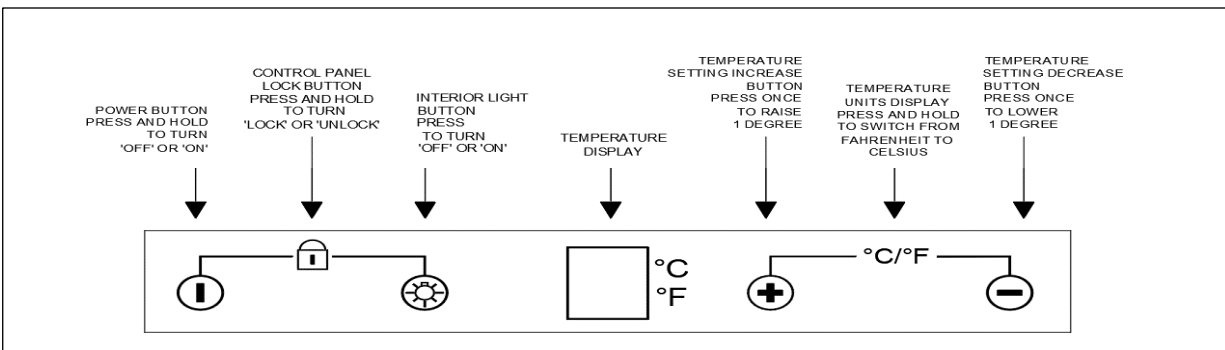

### **Interior Light**

The unit is equipped with an interior LED light that turns ON when the door is open. Opening the door automatically shuts off the interior fan at the same time. You can press the button with lite symbol on the digital control panel to manually turn the light off or on.



### **Defrosting**

The unit defrosts automatically in normal operating conditions. The evaporator behind the rear wall of the unit defrosts automatically. The resulting condensation is collected in the drainage channel behind the rear wall of the unit and flows through the drainage hole into the drip tray by the compressor where it evaporates. Please note, if the door is opened in a high heat or high humidity location it may cause frost to accumulate on the evaporator. If the frost pattern does not clear within 24 hours, your unit will require manual defrosting.



Press the button shown for 6 seconds to start defrosting the unit. To stop the defrost process press the button for 6 seconds.

### **Temperature Alarm**

If the storage temperature is not cold enough an audible alarm will occur, and the temperature display will begin flashing. Listed below are possible reasons for temperature being too high:

- Warm or room temperature being placed inside.
- The door was open long enough to allow warm outside air to raise the temperature.
- Prolonged power failure.
- Refrigerator is not functioning properly.

The refrigerator temperature alarm will shut off and the temperature display will stop flashing when the refrigerator temperature is sufficiently cold again.

The evaporator behind the rear wall of the unit defrosts automatically. The resulting condensation is collected in the drainage channel behind the rear wall of the unit and flows through the drainage hole into the drip tray by the compressor where it evaporates.

Please note, if the door is opened in a high heat or high humidity location it may cause frost to accumulate on the evaporator. If the frost pattern does not clear within 24 hours, your unit will require manual defrosting.

### **Door Alarm**

If the door is left open for more than 60 seconds, an audible alarm will sound. Pressing any button once will turn the alarm off.

### **Door Lock**

The door of your unit has a lock and key provided. These should be in the plastic bag containing the owner's manual. To lock the door, insert the key in the door's lock (make sure the pin for the lock is engaged) and turn it clockwise or counter clockwise to unlock the door. When not in use store the key in a secure location for safe keeping.

### **Shelf Install or Rearranging Preparation**

First, remove all the items from the shelves.

Position the shelf supports inside the racks on the sides as shown below at the level you require and number of shelves you'll be using.

### **Installing the Shelves**

Make sure you have the door open all the way to prevent damaging the door gasket with the shelves when installing them firmly on to the supports.

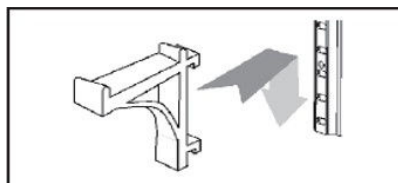



## **Cleaning Your Appliance**

- Turn off the appliance. Unplug the power cord and remove all items including the shelves.

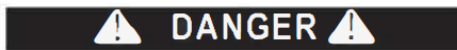

**FAILURE TO UNPLUG THE APPLIANCE DURING COULD RESULT IN ELECTRIC SHOCK OR OTHER PERSONAL INJURY.**

- Wash the inside surfaces with a solution of warm water and baking soda (about 2 tablespoons of baking soda per 1 gallon of water).
- Wash the shelves with a mild detergent solution.
- Wring out excess water from sponge or cleaning cloth before cleaning around control panel display, or electrical parts.
- Wash the outside of the unit with a solution of warm water and mild detergent. Rinse well and dry with a clean, soft cloth towel.
- When cleaning the outside of the unit be sure to use cleansers that are designated for stainless steel. Do not use steel wool scrubbing pads or a wire brush.

## **Power Failure**

- Your refrigerator will maintain its temperature for a few hours if the door is kept closed in the event of a power failure. If the power failure continues, you will need to remove the contents that are at risk.

## **Vacation Periods or times of (Non-Use)**

**Short Vacations** / Less than 3 weeks, leave the unit on.

**Long Vacations** / Longer than 3 weeks. Remove the contents, unplug the unit and follow the cleaning instructions for interior and exterior.

**Note:** Odors or Mold growth can be avoided by blocking the door from fully closing, but with care not to harm the door gasket.

## **Moving Your Appliance**

- 1) Remove all items.
- 2) Remove the shelves or use tape to secure them in place.
- 3) Turn the adjustable feet clockwise until they all the way in to avoid damaging them.
- 4) Tape the door shut.
- 5) Use moving blankets or equivalent to protect the outside while moving.
- 6) Always keep the unit in the upright position, never place on its side or upside down.

## **Energy Saving Tips**

- The appliance should be in the coolest area of the room or outdoor location, away from heat producing appliance and out of direct sunlight.
- Ensure the unit is adequately ventilated. Never cover air vents.
- Do not keep the door any longer than necessary.
- Let hot foods cool to room temperature before placing in the unit. Overloading the unit forces the compressor to run longer.
- Be sure to wrap foods properly, and wipe containers dry before placing them in unit. This cuts down on frost build up inside the unit.
- Unit shelves and storage bins should not be lined with aluminium foil, wax paper or paper towels. These liners interfere with air circulation resulting in less operating efficiency.
- Organize and label stored items to reduce door opening or extended searching for items.
- Remove as many items as needed while avoiding opening door repeatedly. Always close door as soon as possible.

## **Appliance Disposal**

### **Before disposal of the appliance.**

1. Disconnect the main plug from the main socket.
2. Cut off the main cable and discard it.

### **Correct disposal of this appliance.**

To prevent possible harm to the environment or human health from uncontrolled waste disposal, recycle it responsibly to promote the sustainable reuse of material resources. To return your used device, please use your local return and collection system, or contact the retailer where the product was purchased. They can take this product for environmentally safe disposal.



This symbol on the product, or in its packaging, indicates that this product may not be treated as household waste. Instead, it should be taken to the appropriate waste collection point for the recycling of electrical and electronic equipment. By ensuring this product is disposed of correctly, you will help prevent potential negative consequences for the environment and human health, which could otherwise be caused by the inappropriate waste handling of this product. For more detailed information about the recycling of this product, please contact your local council, your household waste disposal service, or the shop where you purchased the product.



**TROUBLESHOOTING**

If you've checked the table below and find that you still need help with your appliance, call our Customer Service Facility at 1800-521-2855 or <https://bullbbq.com/contact/> We will do our best to answer your questions.

<b>TROUBLE SHOOTING GUIDE</b>		
<b>PROBLEM</b>	<b>POSSIBLE CAUSE</b>	<b>REMEDY</b>
Appliance does not operate.	The appliance is turned off.	Switch on the appliance.
	Appliance is not connected to a power supply.	Connect the appliance.
	Tripped circuit breaker or a blown fuse.	Switch circuit breaker or replace fuse.
Appliance is not cold enough.	The temperature is not set correctly.	Check the set temperature
	The ambient temperature could require a lower setting.	Change setting to a lower temperature.
	The door was opened too often.	Do not open door more than often than necessary.
	The door was not completely closed.	Close door properly.
	Door is not hermetically sealed.	Check the door seal and clean or replace.
	The condenser is too dirty.	Clean the condenser when necessary.
	The ventilation opening is blocked or too dusty.	Clear the obstructions and remove the dust.
Appliance turns itself on or off frequently.	The room temperature is higher than average.	Put the appliance in a cooler place.
	A large amount of food has been added to the unit.	Leave the appliance closed until the set temperature has been reached.
	The door is open too often.	Do not open door more than often than necessary.
	The door is not closed completely.	Close door properly.
	The door gasket does not seal properly.	Check the door seal and clean or replace.
The interior light does not work	The light was switched off on the control panel	Switch on the light
	Appliance is not connected to a power supply.	Connect the appliance.
	Tripped circuit breaker or a blown fuse.	Switch circuit breaker or replace fuse.
Vibrations	The appliance was not properly levelled.	Level the appliance with the adjustable feet.
Excessive noise	The appliance was not properly levelled.	Level the appliance with the adjustable feet.
	The rattling noise may come from the flow of refrigerant, which is normal. As the cycle ends, you may hear gurgling sounds caused by the flow of refrigerant in the appliance. If temperature fluctuations occur, the contraction and expansion of the inner walls may cause popping and cracking noises.	
The door will not close.	The appliance was not properly levelled.	Level the appliance with the adjustable feet.
	The door was reversed and not properly installed.	Check the door hinge and reassemble correctly.
	The door gasket is dirty.	Clean the door gasket.
	The shelves are out of position.	Check the shelves and refit correctly.
The temperature alarm and the temperature display flash	Has the appliance door been open for longer than 60 seconds? If not, then the temperature has risen higher or fallen lower than the temperature than it has been set to.	If yes, close the door and let it run until it reaches the temperature setting
	The door is open too often.	Do not open door more than often than necessary.
	The ventilation opening is blocked or too dusty.	Clear the obstructions and remove the dust.
	A lengthy interruption in the power supply	If yes, close the door and let it run until it reaches the temperature setting
	A large amount of food has been added to the unit.	Leave the appliance closed until the set temperature has been reached.



### REGISTERING YOUR REFRIGERATOR

Thank you for purchasing your Bull Outdoor Products Refrigerator. To validate your Limited Warranty, you must submit the completed the Warranty Registration Form within 90 days from the date of purchase. Registration can be completed on-line at <https://bullbbq.com/register> or by sending the completed Warranty Registration Form and copy of your Purchase Receipt or Invoice as proof of purchase to:  
**BULL OUTDOOR PRODUCTS, INC.**  
 1011 East Pine St. Lodi, CA 95240

For Warranty Claims or Replacement Parts ordering, please fill out the area provided below:

**PRODUCT INFORMATION REFERENCE CARD**

1) Model # \_\_\_\_\_  
 2) Serial # \_\_\_\_\_  
 (The Serial Number is encoded with essential information for ordering replacement parts or submitting Warranty claims. Location of Serial Number and Model No. is shown below)  
 3) Date of Purchase \_\_\_\_\_  
 4) Copy of your Purchase Receipt or Invoice.  
 Warranty Questions call Customer Service at (800) 521-2855

### SERIAL NUMBER LOCATION

The model and serial number is located inside your refrigerator on the upper left side.

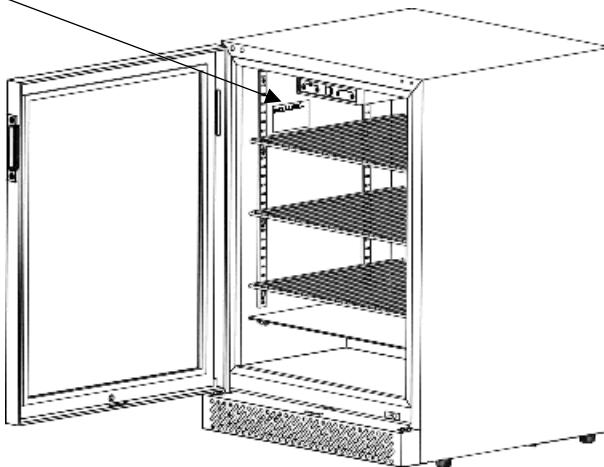

### HOW TO ORDER REPLACEMENT PARTS

This is where your Product Information Reference Card will come in handy for supplying necessary info needed by your Authorized Dealer to assure you get the correct part(s) for your refrigerator. If you don't have the card, you can still get the model number and number located inside your refrigerator on the upper left side. This information is required for parts orders.

**Please refer to your owner's manual parts list and illustration to identify what you need.**

**To Order Replacement Parts on-line go to:** <https://www.bullbbq.com/buy-parts>

**Ordering Parts by phone:** We are ready to help with two regional suppliers open 8:00 am to 5:00 pm Monday through Friday.

For West Region,  
 please call  
**(800) 258-6810**



For East Region,  
 please call  
**(800) 229-3056**

**WARNING:** Use of any part that is not factory authorized will void your warranty and may be dangerous.



**REPLACEMENT PARTS LIST MODEL NO. 13100 (WARRANTY PERIOD FOR ALL PARTS IS 1 YEAR)**

REF # USED ON EXPLODED VIEW	BULL PART #	DESCRIPTION	QTY
1	13726	LOWER DOOR HINGE	1
2	13727	LOWER DOOR HINGE DECORATIVE PANEL	2
3	13706	K-BAR	4
4	12103	CONTROL PANEL	1
5	13701 13716	FAN	1
6	13728	EVAPORATOR FAN COVER	1
7	13729	TEMPERATURE SENSING HEAD COVER	1
8	13730	AUTOMATIC DOOR CLOSING BUSHING LEFT SIDE	1
9	13731	ADJUSTABLE LOWER DOOR HINGE	1
10	13103	KICK PLATE	1
11	13704	SHELF CLIP	12
12	13708	GLASS SHELF	1
13	13707	WIRE SHELF	3
14	13733	PILLAR SWITCH	1
15	13714	LEVELING FEET	4
16	13734	COMPRESSOR COMPARTMENT REAR GRID	1
17	13101	DOOR	1
18	13102	PREMIUM DOOR GASKET	1

**MODEL NO. 13100 REPLACEMENT PARTS LIST EXPLODED VIEW**

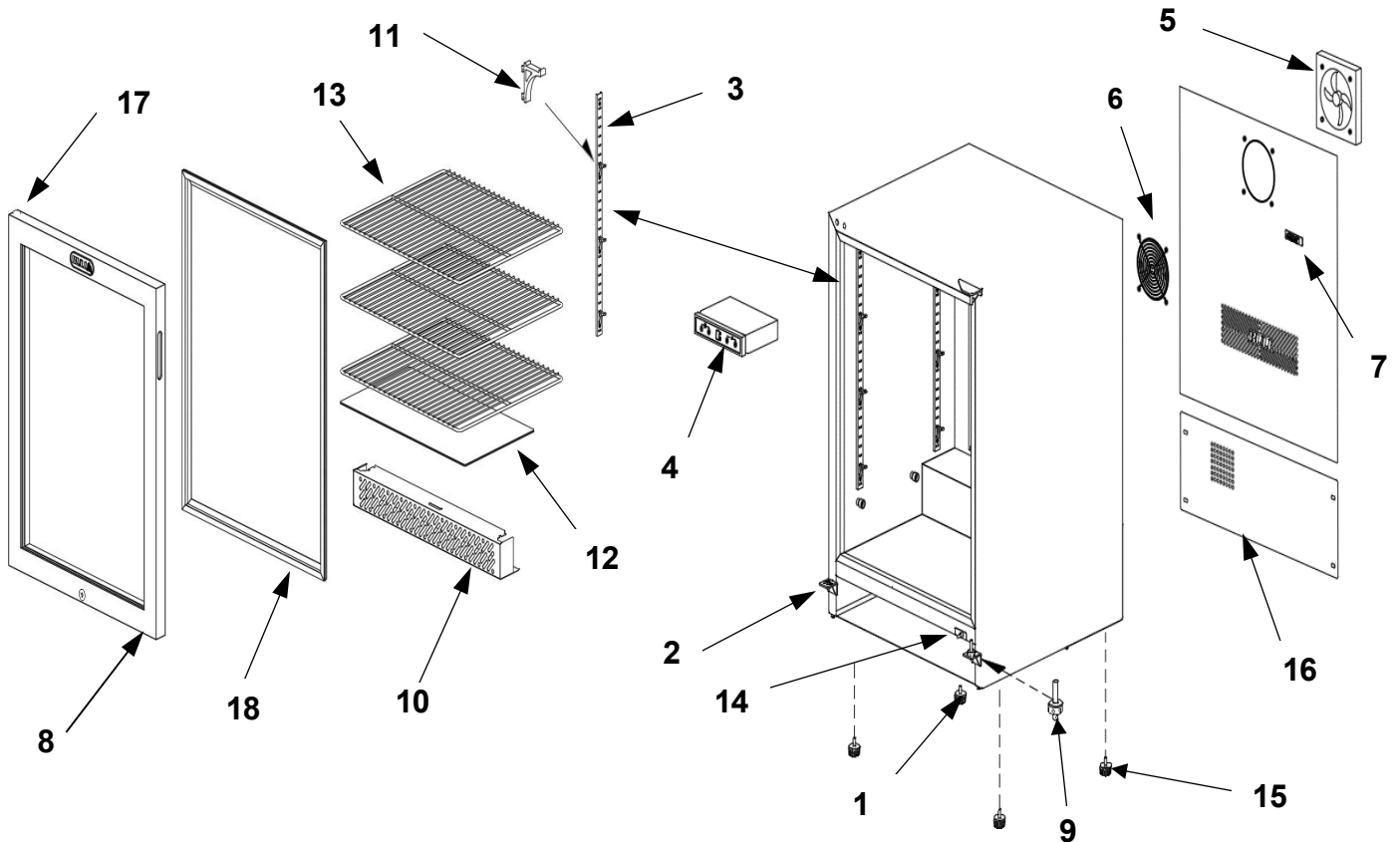

**WARNING:** Use of any part that is not factory authorized will void your warranty and may be dangerous.





# Warranty Policy

**THIS LIMITED WARRANTY GIVES YOU SPECIFIC LEGAL RIGHTS. YOU MAY ALSO HAVE OTHER RIGHTS, WHICH VARY FROM STATE TO STATE.**

**THIS LIMITED WARRANTY CAN ALSO BE FOUND ON OUR WEB SITE AT:**

<https://www.bullbbq.com/support-warranty> (United States Customers)

<https://bullbbq.eu/customer-care/#warranty-registration-form> (International Customers)

**AND IN THE OWNER'S/INSTALLATION MANUAL THAT WE PROVIDE WITH OUR PRODUCT.**

**THIS LIMITED WARRANTY IS SUBJECT TO THE EXCLUSIONS, CONDITIONS AND LIMITATIONS SET FORTH BELOW.**

**ANY IMPLIED WARRANTIES IMPOSED BY LAW, INCLUDING WITHOUT LIMITATION THE IMPLIED WARRANTIES OF MERCHANTABILITY AND FITNESS FOR A PARTICULAR PURPOSE, ARE LIMITED IN DURATION TO THE DURATION OF THIS EXPRESS LIMITED WARRANTY. SOME STATES DO NOT ALLOW LIMITATIONS ON HOW LONG AN IMPLIED WARRANTY LASTS, SO THE ABOVE LIMITATION MAY NOT APPLY TO YOU.**

## **WHO MAY USE THIS WARRANTY?**

**BULL OUTDOOR PRODUCTS, INC.** located at address 1011 East Pine St. Lodi, CA. 95240

("we") extend this limited warranty only to the consumer who originally purchased the product ("you") at the original site of delivery or installation. It does not extend to any subsequent owner or other transferee of the product. It does not apply to products installed in any rental, commercial or non-residential application. Examples of excluded applications include, but are not limited to day care centers, schools, bed and breakfast centers, churches, private clubs, fire stations, club houses, common areas in multi-family dwellings, restaurants, hotels, nursing homes, food service locations and institutional food service locations.

## **WHAT DOES THIS WARRANTY COVER?**

This limited warranty covers defects in materials and workmanship of the product and product components identified below for the Warranty Periods defined below.

## **WHAT IS THE PERIOD OF COVERAGE?**

This limited warranty starts on the date of your purchase and lasts for the time or time periods specified above (the "**Warranty Period**"). The Warranty Period is not extended if we repair or replace the product. We may change the availability of this limited warranty at our discretion, but any changes will not be retroactive.





## Warranty Policy (Continued)

**Grilling/Pizza Accessories and Grill Covers DO NOT include a warranty period.**

### **Grill Warranty Periods**

The following parts are covered for **1 year** on all our current gas grill models:

- The lid, control panel, grease tray, bezels, knobs, temperature gauge, valves, regulator, flex tubes, rotisserie burner, transformer, and all components of the lighting system.

The following parts are covered for **3 years** on all our current gas grill models:

- The manifold, handle end caps, flame tamers, heat shields, and warming rack.

The following parts are covered for the **lifetime** on all our current gas grill models:

- Insert assembly and the grates.

The warranty period for the grill burners varies by type:

- Cast stainless steel burners - **Lifetime**
- Welded stainless steel burners – **5 years**
- Porcelain coated burners – **3 years**

The warranty period for the charcoal grill is **1 year** on all parts, except for the insert assembly, which is covered for **5 years**.

### **Component Warranty Periods**

All the parts for our components /grill carts/refrigerators/kegerators/drawers/doors/refrigerator frames/grill jackets/finishing frames/ice chest/sinks/bar center are covered for **1 year** with these exceptions:

- **Power Burner**
  - The insert/grates are **lifetime** covered parts.  
The manifold/burner are covered for **3 years**.
- **Searing Station/Slide in Double Sideburner**
  - The grates are covered for **lifetime**,
  - The insert for **5 years**, and
  - The manifold for **3 years**.
- **Single Sideburner**
  - The grates are covered for **5 years** and
  - The burner for **3 years**.
- **Sidekick**
  - The burner is covered for **3 years**.

### **Pizza Ovens/Islands/Fire Features Warranty Periods**

- All the parts and construction materials are covered for **1 year**.



## Warranty Policy (Continued)

### WHAT DOES THIS WARRANTY NOT COVER?

This limited warranty does not cover any damage due to:

- Transportation.
- Storage
- Improper installation or use
- Use on improper fuel/gas supply.
- Failure to follow the product instructions or to perform any preventive maintenance.
- Modifications.
- Unauthorized repair.
- Normal wear and tear, rust, corrosion, oxidation, or discoloration.
- External causes such as accidents, abuse, or other actions or events beyond our reasonable control.

### WHAT OPTIONS ARE OFFERED BY BULL OUTDOOR PRODUCTS UNDER THIS WARRANTY?

With respect to any defective product claim made during the Warranty Period, we will, in our sole discretion:

- Replace such product (or the defective part) free of charge or refund the purchase price of such product.

### WHAT IS EXCLUDED BY BULL OUTDOOR PRODUCTS UNDER THIS WARRANTY?

- We will not pay for shipping charges for repaired or replacement parts, or for any labor or labor related charges.
- We will not pay for any accessory products or ancillary products purchased by you for use in connection with the product.

### HOW DO YOU NOTIFY BULL CUSTOMER SERVICE OF A POTENTIAL WARRANTY ISSUE?

Our Customer Service is ready to help. Here's how to reach us:



By Phone (800) 521-2855 Monday through Friday from 8:00 a.m. to 5:00 p.m. (EDT)



To submit a warranty claim on-line or message go to <https://www.bullbbq.com/support-warranty>

### LIMITATION OF LIABILITY

**THE REMEDIES DESCRIBED ABOVE ARE YOUR SOLE AND EXCLUSIVE REMEDIES AND OUR ENTIRE LIABILITY FOR ANY BREACH OF THIS LIMITED WARRANTY. OUR LIABILITY SHALL UNDER NO CIRCUMSTANCES EXCEED THE ACTUAL AMOUNT PAID BY YOU FOR THE DEFECTIVE PRODUCT, NOR SHALL WE UNDER ANY CIRCUMSTANCES BE LIABLE FOR ANY CONSEQUENTIAL, INCIDENTAL, SPECIAL OR PUNITIVE DAMAGES OR LOSSES, WHETHER DIRECT OR INDIRECT.**

**SOME STATES DO NOT ALLOW THE EXCLUSION OR LIMITATION OF INCIDENTAL OR CONSEQUENTIAL DAMAGES, SO THE ABOVE LIMITATION OR EXCLUSION MAY NOT APPLY TO YOU.**