

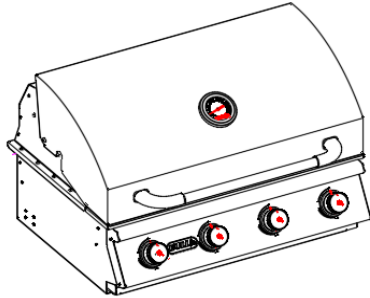

30 INCH GRILL HEADS OWNER'S MANUAL

OUTLAW

SKU# 26038 LP
SKU# 26039 NG



LONESTAR SELECT

SKU# 87048 LP
SKU# 87049 NG

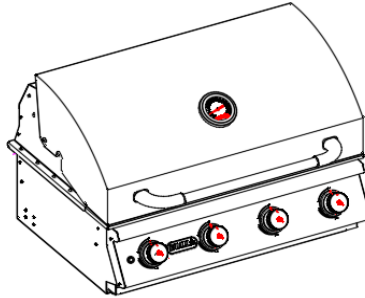

ANGUS

SKU# 47628 LP
SKU# 47629 NG

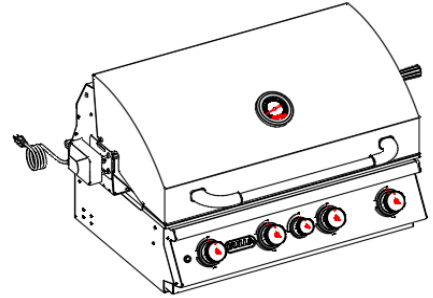

(LP) LIQUID PROPANE (NG) NATURAL GAS

DANGER

If you smell gas:

- Shut off gas to the appliance.
- Extinguish any open flame.
- Open lid.
- If odor continues, keep away from the appliance and immediately call your gas supplier or your fire department.

WARNING

- Do not store or use gasoline or other flammable liquids or vapors in the vicinity of this or any other appliance.
- An LP cylinder not connected for use shall not be stored in the vicinity of this or any other appliance.



USA EDITION



TABLE OF CONTENTS

PAGE #2

SAFETY INSTRUCTIONS

GRILL OPERATIONAL SAFETY 3

CHECKING FOR GAS LEAKS 3

LIQUID PROPANE CYLINDER SAFETY 4

LIQUID PROPANE CYLINDER SAFETY DURING 'OFF SEASON' 5

LP TO NATURAL GAS CONVERSION 5

NATURAL GAS SAFETY 5- 6

INSTALLATION INSTRUCTIONS

GRILL LOCATION AND INSTALLATION NOTES FOR INSTALLER 6

GRILL OVERHEAD VENTILATION 7

VENTILATION REQUIREMENTS FOR GRILL ENCLOSURES 8

LP GAS TANK GUIDELINES AND LP GAS TANK CONNECTION DIAGRAM WHEN USING AN ENCLOSURE 9

LP GAS TANK RETENTION AND GRILL INSTALL CUT-OUT DIMENSIONS 10

NATURAL GAS CONNECTION SPECIFICATIONS 11

LONESTAR AND ANGUS GRILL LIGHT SYSTEM TRANSFORMER INSTALLATION 12

GRILL OPERATION AND COOKING GUIDELINES

GRILL 'FIRST USE' LIGHTING PROCEDURE 13

GRILL STANDARD LIGHTING PROCEDURE 14

LIGHTING GRILL MANUALLY / LIGHTING THE INFRARED BACK BURNER (ANGUS GRILL) 15

COMPONENT INSTALLATION AND COOKING TEMPERATURE SETTINGS 16

ROTISSERIE SYSTEM OPERATION 17

GRILL BURNER REMOVAL INSPECTION / CLEANING BURNERS AND GAS VALVE ORIFICES BURNER CLEANING

BURNER REMOVAL INSTRUCTIONS 18

BURNER INSPECTION AND CLEANING 19

BURNER SHUTTER CLIP INSPECTION AND ADJUSTMENT 19

INSTALLING BURNERS BACK INTO GRILL / BURNER IGNITOR -ELECTRODE CHECK 20

GRILL LIGHTING SYSTEM

LIGHT BULB REPLACEMENT AND CONNECTION DIAGRAM 21

ANNUAL CLEANING & MAINTENANCE

REQUIRED INSTALLATION, OPERATION AND MAINTENANCE INSTRUCTIONS_REFERENCE PAGE 23

TROUBLESHOOTING

IF GRILL FAILS TO OPERATE PROPERLY 24

YELLOW FLAME AND FLASHBACK 24

HOW TO REGISTER YOUR GRILL, SERIAL NO. LOCATION, REPLACEMENT PART ORDERING 25

OUTLAW REPLACEMENT PARTS LIST AND REFERENCE DRAWING 26-27

LONESTAR SELECT REPLACEMENT PARTS LIST AND REFERENCE DRAWING 28-29

ANGUS REPLACEMENT PARTS LIST AND REFERENCE DRAWING 30-31

ROTISSERIE PARTS LIST AND EXPLODED ILLUSTRATION 32

LIMITED WARRANTY POLICY 33-35

READ THIS ENTIRE MANUAL CAREFULLY AND RETAIN FOR FUTURE REFERENCE.

BE SURE YOUR GRILL IS PROPERLY INSTALLED, ASSEMBLED AND CARED FOR. FAILURE TO FOLLOW THESE INSTRUCTIONS MAY RESULT IN SERIOUS BODILY INJURY AND/OR PROPERTY DAMAGE. IF YOU HAVE QUESTIONS CONCERNING ASSEMBLY OR OPERATION, CONSULT YOUR DEALER, GAS APPLIANCE SERVICE REPRESENTATIVE OR YOUR GAS COMPANY.

- NOTE TO INSTALLER: LEAVE THESE INSTRUCTIONS WITH THE CONSUMER AFTER INSTALLATION.

- NOTE TO THE CONSUMER: RETAIN THESE INSTRUCTIONS FOR FUTURE REFERENCE.

- THIS OUTDOOR COOKING GAS APPLIANCE IS NOT INTENDED TO BE INSTALLED IN OR ON RECREATIONAL VEHICLES AND/OR BOATS.

*FOR WARRANTY PURPOSES, PLEASE RECORD YOUR MODEL NUMBER, SERIAL NUMBER AND DATE OF PURCHASE ON THE REGISTRATION CARD PER PAGE 25 AND ATTACHING A COPY OF YOUR RECEIPT OR INVOICE.

WARNING: THIS PRODUCT CAN EXPOSE YOU TO CHEMICALS INCLUDING CARBON MONOXIDE, WHICH IS KNOWN TO THE STATE OF CALIFORNIA TO CAUSE BIRTH DEFECTS OR OTHER REPRODUCTIVE HARM. FOR MORE INFORMATION VISIT www.P65Warnings.ca.gov

WARNING: Fuels used in gas or oil-fired appliances and the products of combustion of such fuels, contain chemicals known to the State of California to cause cancer, birth defects and/or reproductive harm. This warning is issued pursuant to California Health & Safety Code Sec. 25249.6.

v.2024.12.09

TO LEARN MORE ABOUT YOUR GRILL'S FEATURES GO TO ONE OF THE LINKS BELOW:
 ANGUS GRILL <https://youtu.be/p41jagadnMU>
 LONESTAR GRILL https://youtu.be/8rk_EiJH6vk
 OUTLAW GRILL <https://youtu.be/Rudt90UYuKg>



GRILL OPERATION SAFETY INSTRUCTIONS



WARNING! FOR YOUR SAFETY, READ THE GUIDELINES BELOW FOR ASSEMBLY AND OPERATION OF YOUR GRILL YOUR GAS GRILL IS ONLY FOR OUTDOOR USE.

PROTECT CHILDREN: DO NOT ALLOW CHILDREN TO OPERATE THE GRILL. KEEP THEM AWAY FROM THE GRILL DURING USE, AND UNTIL THE GRILL HAS COOLED COMPLETELY.

WARNING: DO NOT USE YOUR GAS GRILL UNDER EXTENDED AWNINGS, GARAGES, PORCHES, BREEZEWAYS, SHEDS OR OTHER ENCLOSED AREAS. FAILURE TO DO SO COULD RESULT IN A FIRE

DANGER: DO NOT PUT GRILL IN STORAGE OR TRAVELMODE IMMEDIATELY AFTER USE. ALLOW GRILL TO COOL TO TOUCH BEFORE MOVING OR STORAGE. FAILURE TO DO SO COULD RESULT IN FIRE RESULTING IN PROPERTY DAMAGE, PERSONAL INJURY OR DEATH

ADDITIONAL SAFETY INSTRUCTIONS:

- 1) THIS GRILL IS NOT INTENDED FOR USE IN OR ON RECREATIONAL VEHICLES AND OR BOATS.
- 2) DO NOT PLACE GRILL UNDER OR ON TOP OF A SURFACE THAT WILL BURN.
- 3) DO NOT ALLOW OBSTRUCTION OR RESTRICTION TO THE FLOW OF COMBUSTION AND VENTILATION AIR AROUND GRILL HOUSING.
- 4) GRILL CLEARANCE FROM THE BACK AND SIDE OF ANY COMBUSTIBLE SURFACE MUST BE AT LEAST 21 INCHES. DO NOT STORE OR USE GASOLINE, OR OTHER LIQUIDS EMITTING FLAMMABLE VAPORS IN THE VICINITY OF GRILL OR ANY OTHER APPLIANCES.
- 5) DO NOT STORE EMPTY OR FULL SPARE LP GAS CYLINDERS AND/OR CHEMICALS UNDER OR NEAR GRILL OR ANY OTHER APPLIANCES.
- 6) KEEP THE FUEL HOSE AND ELECTRICAL CORDS AWAY FROM HOT SURFACES AND DRIPPING GREASE. CHECK AND CLEAN BURNER VENTURI TUBES FOR INSECTS AND DEBRIS. A CLOGGED TUBE CAN LEAD TO A FIRE BENEATH THE GRILL.
- 7) KEEP THE VENT OPENINGS OF THE CYLINDER ENCLOSURE FREE AND CLEAR FROM DEBRIS. CLEAN OUTDOOR COOKING GAS APPLIANCE WITH RECOMMENDED CLEANING AGENTS.
- 8) AVOID UNNECESSARY TWISTING OF THE HOSE. VISUALLY INSPECT THE HOSE PRIOR TO EACH USE FOR CUTS, CRACKS, EXCESSIVE WEAR OR OTHER DAMAGE AND REPLACE IF NECESSARY. THE REPLACEMENT HOSE SHOULD BE SPECIFIED BY THE MANUFACTURER.
- 9) NEVER LIGHT GRILL WITH LID CLOSED OR BEFORE CHECKING TO ENSURE BURNER TUBES ARE FULLY SEATED OVER GAS VALVE ORIFICES.
- 10) NEVER LEAN OVER COOKING SURFACE WHILE LIGHTING GRILL. USE BARBECUE TOOLS WITH WOOD HANDLES AND GOOD QUALITY INSULATED OVEN MITTS WHEN OPERATING GRILL.
- 11) NEVER PLACE OBJECTS OR UTENSILS ON TOP OF GRILL LID.

WARNING! FOR YOUR SAFETY...

- 1) DO NOT STORE OR USE GASOLINE OR OTHER FLAMMABLE VAPORS AND LIQUIDS IN THE VICINITY OF THIS OR ANY OTHER APPLIANCE.
- 2) DO NOT STORE EMPTY OR FULL SPARE GAS CYLINDERS AND OR CHEMICALS UNDER OR NEAR THIS OR ANY OTHER APPLIANCE.
- 3) KEEP THE FUEL HOSE AWAY FROM HOT SURFACES. PROTECT THE FUEL HOSE FROM DRIPPING GREASE. AVOID UNNECESSARY TWISTING OF THE HOSE. VISUALLY INSPECT THE HOSE PRIOR TO EACH USE FOR CUTS, CRACKS EXCESSIVE WEAR OR OTHER DAMAGE AND REPLACE IF NECESSARY.
- 4) NEVER TEST FOR GAS LEAKS WITH A LIGHTED MATCH OR OPEN FLAME.
- 5) NEVER LIGHT GRILL WITH LID CLOSED OR BEFORE CHECKING TO ENSURE BURNER TUBES ARE FULLY SEATED OVER GAS VALVE ORIFICES.
- 6) NEVER LEAN OVER COOKING SURFACE WHILE LIGHTING GRILL. USE BARBECUE TOOLS WITH WOOD HANDLES AND GOOD QUALITY INSULATED OVEN MITTS WHEN OPERATING GRILL.
- 7) KEEP ANY ELECTRICAL SUPPLY CORD AND THE FUEL SUPPLY HOSE AWAY FROM ANY HEATED SURFACES.

DANGER! IF YOU SMELL GAS...



- 1) SHUTOFF GAS TO THE APPLIANCE AS ITS SOURCE.
- 2) EXTINGUISH ANY OPEN FLAME
- 3) OPEN GRILL LID TO RELEASE ANY ACCUMULATION OF FUMES.
- 4) IF GAS ODORS PERSISTS, IMMEDIATELY CONTACT YOUR GAS SUPPLIER OR FIRE DEPARTMENT.

CHECKING FOR GAS LEAKS NEVER TEST FOR GAS LEAKS WHILE THE GRILL IS LIT!

You must follow the steps below to check for leaks on LP Gas Grills prior to first use or start of a new season and whenever the gas cylinder is changed on LP Gas Grills.

- 1) TURN OFF HEAT CONTROL VALVE(S), AND THEN TURN ON GAS AT SOURCE.
- 2) MAKE A SOAP SOLUTION BY MIXING ONE-PART LIQUID DETERGENT AND ONE-PART WATER.
- 3) APPLY THE SOAP SOLUTION TO ALL GAS CONNECTIONS. IF AIR BUBBLES APPEAR IN THE SOAP SOLUTION IT MEANS THE CONNECTIONS ARE NOT PROPERLY SEALED AND NEED TO BE TIGHTEN OR REPAIRED AS NEEDED. IF YOU HAVE A GAS LEAK THAT YOU CANNOT REPAIR, TURN OFF THE GAS AT THE SOURCE, DISCONNECT THE FUEL LINE FROM THE GRILL AND IMMEDIATELY CALL YOUR GRILL DEALER AND GAS SUPPLIER FOR PROFESSIONAL ASSISTANCE

WARNING: IF THESE GUIDELINES ARE NOT FOLLOWED, FIRE CAUSING SERIOUS INJURY OR DEATH MAY OCCUR.

 SAFETY INSTRUCTIONS BEWARE OF CLOGGED BURNERS DUE TO SPIDER WEBS CAUTION: BURNERS MUST BE INSPECTED AND CLEANED BEFORE FIRST USE Spiders and small insects occasionally spin webs or make nests in the burners during warehousing, transit and/or after long periods of non-use. These webs can lead to a gas flow obstruction, which could result in a fire in and around the burner venturi tubes. This type of fire is known as "FLASH-BACK" and can cause serious damage to your grill and create an unsafe operating condition for the user. Although an obstructed burner tube is not the only cause of "FLASH BACK" it is the most common cause, and frequent inspection and cleaning of the burners is necessary. WARNING NEVER cover grill slots, holes, or openings in the grill bottom, or cover an entire cooking grate with material such as aluminum foil. Doing so blocks air flow through the grill and may cause carbon monoxide poisoning. Aluminum foil linings may trap heat causing a fire hazard. 



⚠ LIQUID PROPANE (LP) CYLINDER SAFETY GUIDELINES

YOUR PROPANE GAS GRILL IS DESIGNED TO OPERATE ON PROPANE GAS ONLY, AT A PRESSURE REGULATED AT 11" WATER COLUMN (W.C.) WHEN EQUIPPED WITH THE CORRECT PROPANE ORIFICES ON THE VALVES AND A PROPANE REGULATOR ON THE SUPPLY LINE REGULATED AT THE RESIDENTIAL METER. YOUR PROPANE GAS GRILL IS DESIGNED TO BE USED WITH A STANDARD 20 LB. GAS CYLINDER WITH SIZE OF 46CM (HEIGHT) / 18.1IN * 32CM (WIDTH) / 12.5IN. IN THE UNITED STATES, THE GAS CYLINDER MUST BE CONSTRUCTED AND MARKED IN ACCORDANCE WITH SPECIFICATIONS OF THE US DEPARTMENT OF TRANSPORTATION FOR PROPANE GAS CYLINDERS.

- 1) **WARNING:** ALWAYS KEEP LP GAS CYLINDER SECURELY FASTENED IN AN UPRIGHT POSITION.
- 2) **WARNING!** NEVER CONNECT AN UNREGULATED LP GAS CYLINDER TO THE GRILL.
- 3) DO NOT SUBJECT LP GAS CYLINDERS TO EXCESSIVE HEAT.
- 4) DO NOT STORE SPARE LP GAS CYLINDERS UNDER OR NEAR THIS APPLIANCE.
- 5) DO NOT FILL LP GAS CYLINDER BEYOND 80% FULL.

IF WARNING NOTICES 1 AND 2 ARE NOT FOLLOWED, A FIRE CAUSING SERIOUS INJURY OR DEATH MAY OCCUR

- 6) **CAUTION:** CHANGING THE GAS TANKS MUST BE DONE AWAY FROM ANY SOURCE OF IGNITION.
- 7) LP GAS TANK MUST BE MARKED IN ACCORDANCE WITH THE SPECIFICATIONS FOR LP GAS CYLINDERS, SPHERICAL TANKS AND TUBES FOR TRANSPORTATION OF DANGEROUS GOODS AND COMMISSION, CAN/CSA- B339, APPLICABLE
- 8) LP GAS TANK CONNECTION DEVICE IS COMPATIBLE WITH OUTDOOR COOKING APPLIANCES.
- 9) LP GAS TANK HAS APPROPRIATE VAPOR WITHDRAWAL.
- 10) LP GAS TANK MUST HAVE A LISTED OVERFILLING PREVENTION DEVICE.
- 11) LP GAS TANK MUST INCLUDE A COLLAR TO PROTECT THE CYLINDER VALVE.
- 12) LP GAS TANK USES A TYPE 1 TANK VALVE THAT IS FIRMLY SECURED IN AN UPRIGHT POSITION.
- 13) DO NOT USE AN LP CYLINDER THAT IS DAMAGED.
- 14) VISUALLY INSPECT THE LP HOSE PRIOR TO EACH USE FOR CUTS, CRACKS, EXCESSIVE WEAR OR DAMAGE. IF FOUND ASSEMBLY SHOULD BE REPLACED, USE ONLY THE BULL PART NUMBERS SHOWN IN THE PARTS LIST SUPPLIED WITH THIS UNIT. THE REPLACEMENT HOSE ASSEMBLY SHALL BE SPECIFIED BY THE MANUFACTURER.
- 15) LP GAS PRESSURE REGULATOR AND 31" INCH HOSE ASSEMBLY (BULL PART # 16589) ARE SUPPLIED AND MUST BE USED WITHOUT ALTERATION AND SHOULD ONLY BE USED ON THIS GRILL.
- 16) TO CONNECT TO LP TANK, ATTACH THE BLACK COUPLING NUT ON THE REGULATOR ASSEMBLY TO THE LP TANK BY ROTATING CLOCKWISE DIRECTION (SEE ILLUSTRATION BELOW) UNTIL IT IS COMPLETELY THREADED ONTO THE CYLINDER VALVE BEFORE TURNING THE GAS SUPPLY ON. TO REMOVE TURN THE BLACK COUPLING NUT OF THE HOSE AND REGULATOR ASSEMBLY IN A COUNTER CLOCKWISE DIRECTION.

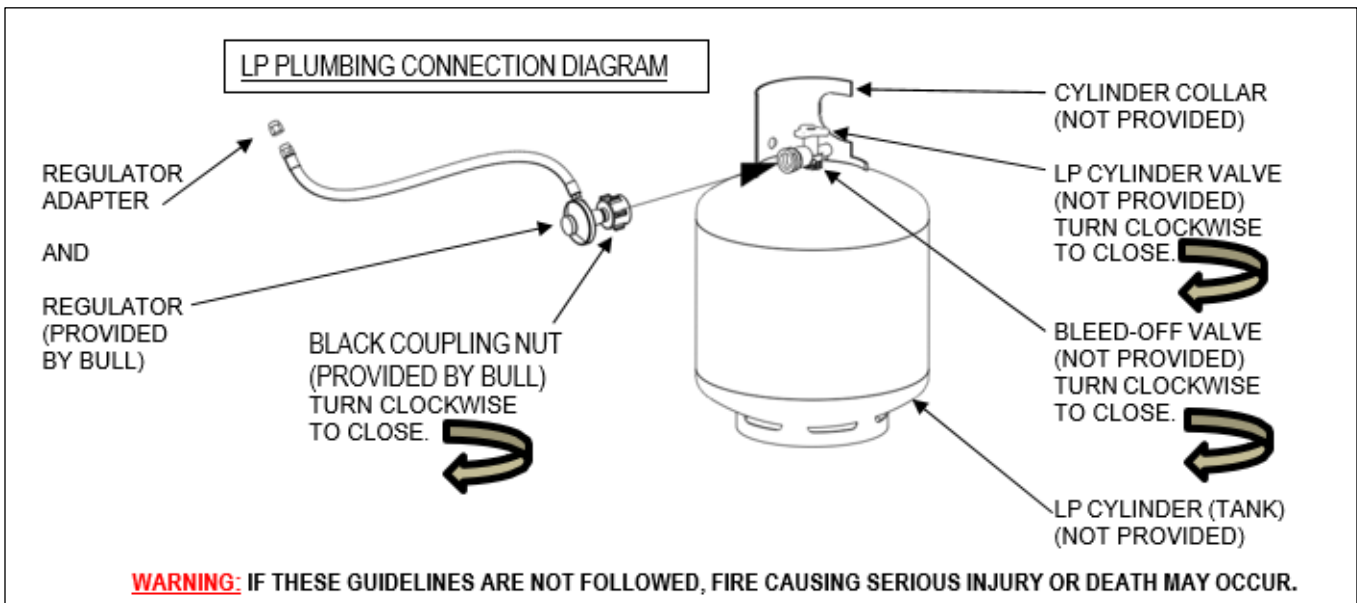



⚠ LIQUID PROPANE (LP) SAFETY GUIDELINES (CONTINUED) WHEN THE OUTDOOR COOKING GAS APPLIANCE IS NOT IN USE

WARNING: WHEN THE OUTDOOR COOKING GAS APPLIANCE IS NOT IN USE, THE GAS SUPPLY **MUST** BE TURNED OFF AT THE SUPPLY CYLINDER. THE STORAGE OF AN OUTDOOR COOKING GAS APPLIANCE INDOORS IS PERMISSIBLE ONLY IF THE CYLINDER IS DISCONNECTED AND REMOVED FROM THE OUTDOOR COOKING GAS APPLIANCE.

- 1) THE LP GAS MUST BE TURNED OFF AT THE SUPPLY CYLINDER.
- 2) DO NOT STORE SPARE LP GAS CYLINDERS UNDER OR NEAR THIS APPLIANCE.
- 3) SPARE LP GAS CYLINDERS MUST BE STORED OUTSIDE IN AN ADEQUATELY VENTILATED AREA THAT IS ISOLATED FROM THE GRILL.
- 4) SPARE LP GAS CYLINDERS MUST BE KEPT OUT OF REACH OF CHILDREN AND MUST NOT BE STORED IN A BUILDING, GARAGE OR ANY OTHER ENCLOSED AREA.
- 5) STORAGE OF AN OUTDOOR COOKING GAS APPLIANCE INDOORS IS PERMISSIBLE ONLY IF THE CYLINDER IS DISCONNECTED AND REMOVED FROM THE OUTDOOR COOKING GAS APPLIANCE
- 6) THE LP GAS CYLINDER MUST BE EQUIPPED WITH AN ARRANGEMENT FOR VAPOR WITHDRAWAL.
- 7) THE LP GAS CYLINDER MUST INCLUDE A COLLAR TO PROTECT THE CYLINDER VALVE.
- 8) PLACE DUST CAP ON CYLINDER VALVE OUTLET WHENEVER THE CYLINDER IS NOT IN USE. ONLY INSTALL THE TYPE OF DUST CAP ON THE CYLINDER VALVE OUTLET THAT IS PROVIDED WITH THE CYLINDER VALVE. OTHER TYPES OF CAPS OR PLUGS MAY RESULT IN LEAKAGE OF PROPANE.

WARNING: If these guidelines are not followed exactly, fire causing severe injury or death or may occur

LIQUID PROPANE GAS TO NATURAL GAS CONVERSION FIRE CAUSING SERIOUS INJURY OR DEATH MAY OCCUR

Gas valves are pre-set at the Bull factory to operate on LP Gas or Natural Gas. If you wish to convert to a different gas type, other than LP or NG, be sure to contact your grill dealer, licensed plumber, or authorized service center for further details. Conversion kits are sold only to professionals to perform conversion service. Failure to properly convert a unit can cause severe injury to yourself and/or others, irreparable damage to your grill and void of warranty.

WARNING: IF THESE GUIDELINES ARE NOT FOLLOWED, FIRE CAUSING SERIOUS INJURY OR DEATH MAY OCCUR.

NATURAL GAS (NG) SAFETY GUIDELINES

Your Natural Gas (G20) grill is intended to use **NATURAL GAS ONLY**. The grill operates at a pressure of 4" water column (wc) or 10 mbar set at the natural gas regulator attached at the back of the grill. Prior to installing gas supply lines, check with your local gas utility or municipality regarding local gas pressure and for building code requirements and instructions or consult a licensed and knowledgeable installer.

NATURAL GAS PLUMBING TO CONNECTION SOURCE GUIDELINES

Refer to the following instructions and illustrations for typical gas supply connections.

We strongly suggest having your gas plumbing and gas connection to your grill be completed by a professional.

IMPORTANT:

Before connecting the grill to gas source, make sure Grill control knobs are in "OFF" position.

Be sure to follow instructions for connecting an appliance to a fixed fuel piping system specifying the use of a rigid pipe, semi-rigid tubing, and/or a connector that complies with the Standard for Connectors for Outdoor Gas Appliances and Manufactured Homes, ANSI Z21.75 * CSA 6.27.

- 1) Install an "ON-OFF" shutoff valve for **OUTDOOR** gas supply source after gas line piping exits outside wall, or before gas piping enters ground.
- 2) Install an "ON-OFF" shutoff valve for **INDOOR** gas supply source to the branch fuel line in an accessible location near the supply line.
- 3) **Do not use** Teflon ® tape or pipe sealant on any flare ends because you will not obtain a leak-free seal.
- 4) Use **only** Pipe sealing compound or pipe thread tape of the type of resistant to the action of natural gas to at least the first three threads of all male pipe threads when making the connection.
- 5) Disconnect your gas grill from fuel source when the gas supply is being tested at high pressures. This appliance and its shutoff valve must be disconnected from the gas supply piping system during any pressure testing of that system at pressures more than 1/2 psig or 37 mbar.

The outdoor cooking gas appliance and its shut-off valve must be disconnected from the gas supply piping system during any pressure testing of that system at test pressures more than 0.5 psi (3.5 kPa). The outdoor cooking gas appliance must be isolated from the gas supply piping system by closing its individual manual shut-off valve during any pressure testing of the gas supply piping system at test pressures equal to or less than 1/2 psi (3.5 kPa).

- 6) **Turn off your gas grill when the gas supply is being tested at low pressures. This appliance must be isolated from the gas supply piping system by closing its individual valve.**

WARNING: IF THESE GUIDELINES ARE NOT FOLLOWED, FIRE CAUSING SERIOUS INJURY OR DEATH MAY OCCUR



NATURAL GAS CONNECTION TO GRILL

! **IMPORTANT:** Bull Outdoor Products does not recommend the use of any quick connection fittings or lines to the unit. The use of these types of fittings or lines could cause low gas flow and reduce the performance of the unit.

- 1) Do not use Teflon ® tape or pipe sealant on any flare ends because you will not obtain a leak-free seal.
- 2) Remove plastic cap from regulator installed on grill.
- 3) Attach stainless steel flex line 3/8" flare-female end to the regulator.
- 4) Attach the other end of flex line to shut-off valve through a nipple.
- 5) Attach a shut-off valve to gas supply pipe.

TO PERFORM GAS LEAK CHECK – REFER TO PAGE 3 OR 13

THE LOCATION AND INSTALLATION OF YOUR GRILL

PLEASE READ THESE INSTRUCTIONS BEFORE INSTALLING YOUR GRILL

Your Built-in Gas Grill comes to you fully assembled. We strongly recommend a professional for your Grill's installation and gas connection needs. These instructions will provide you with the measurements necessary for you or your builder to construct a masonry structure for your outdoor gas grill.

- 1) This gas grill must be installed in accordance with local codes or, if in an area without local codes, with the latest edition of the National Fuel Gas Code ANSI Z223.1. In Canada, installation must conform to the standard CAN/ CGA 1-b149.1 and/or (Installation Code for Gas Burning Appliances and Equipment) and any local codes.
- 2) The outdoor cooking gas appliance, when installed, must be electrically grounded in accordance with local codes or, in the absence of local codes, with the National Electrical Code, ANSI/NFPA 70, or the Canadian Electrical Code, Part I, CSA C22.1.
 - 2a) To protect against electric shock, do not immerse cord or plugs in water or other liquid.
 - 2b) Unplug from the outlet when not in use and before cleaning. Allow it to cool before putting on or taking off part.
 - 2c) **Do not** operate any outdoor cooking gas appliance with a damaged cord, plug, or after the appliance malfunctions or has been damaged in any manner. Contact the manufacturer for repair.
 - 2d) **Do not** let the cord hang over the edge of a table or touch hot surfaces.
 - 2e) **Do not** use an outdoor cooking gas appliance for purposes other than intended.
 - 2f) When connecting, first connect plug to the outdoor cooking gas appliance then plug appliance into the outlet.
 - 2g) Use only a Ground Fault Interrupter (GFI) protected circuit with this outdoor cooking gas appliance.
 - 2h) **Never** remove the grounding plug or use with an adapter of 2 prongs and
 - 2i) Use only extension cords with a 3-prong grounding plug, rated for the power of the equipment, and approved for outdoor use with a W-A marking.
- 3) **Do not** use your gas grill in garages, porches, breezeways, sheds, or other enclosed areas.
- 4) Your gas grill is to be used **OUTDOORS ONLY**, with at least 21 inches of clearance from the back and side of any combustible surface.
- 5) **Do not** place the grill under or on top of any surface that will burn.
- 6) **Do not** obstruct the flow of combustion and ventilation air around the grill housing.

NOTES TO INSTALLER:

- 1) Leave these instructions with the consumer for future reference.
- 2) The grill must be installed in accordance with all local building codes.
- 3) Do not use any combustible materials for this construction.
- 4) We do not endorse the use of combustible flooring materials.
- 5) The minimum horizontal clearance to adjacent combustible surface from side and back of the grill must be **21 inches**.
- 6) Provide 6 inches of clearance behind grill to allow front portion of hood to open and for ventilation purposes.
- 7) Please remove the cotter pins from the burners before installing the unit into an island. See page 17 for cotter pin removal.

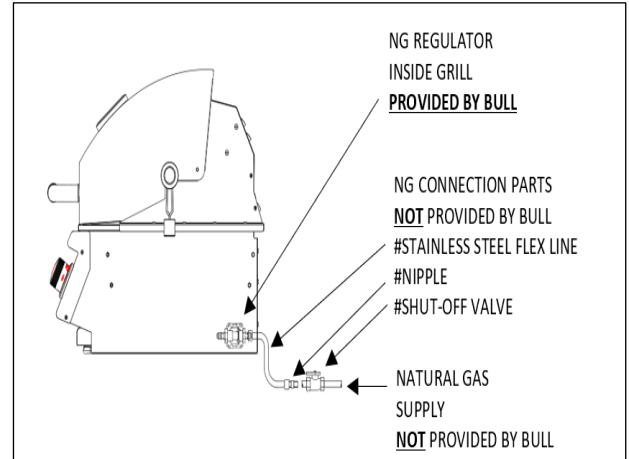

WARNING: IF THESE GUIDELINES ARE NOT FOLLOWED, FIRE CAUSING SERIOUS INJURY OR DEATH MAY OCCUR.



GRILL OVERHEAD VENTILATION INSTRUCTIONS

⚠ IMPORTANT!

DO **NOT** USE OR INSTALL YOUR GRILL IN THE FOLLOWING LOCATIONS:

- INDOORS
- ENCLOSED AREAS
- BREEZEWAYS
- SCREENED-IN PATIOS
- INSIDE A BUILDING

IF THE GRILL LOCATION HAS OVERHEAD CONSTRUCTION PRESENT YOU **MUST** FOLLOW THESE INSTRUCTIONS:

- 1) DO NOT INSTALL GRILL UNDER A COMBUSTIBLE COVER.
- 2) OVERHEAD CONSTRUCTION ABOVE COOKING SURFACES **MUST** BE NON-COMBUSTIBLE AND **MUST** BE BUILT NO LESS THAN 60 INCHES ABOVE THE COOKING SURFACES UNLESS OTHERWISE STATED BY LOCAL BUILDING AND FIRE CODE REQUIREMENTS.
- 3) A VENTILATION HOOD **MUST** BE INSTALLED ABOVE THE COOKING SURFACE WITH A 30 INCHES MINIMUM CLEARANCE BETWEEN VENTILATION HOOD AND COOKING SURFACE
- 4) VENTILATION HOOD **MUST** BE LARGER THEN THE COOKING SURFACE WITH A MINIMUM OF 3 INCHES OF OVERLAP ON EACH SIDE OF COOKING SURFACE
- 5) VENTILATION HOOD **MUST** BE RATED WITH A MINIMUM OF 1200 CFM (CUBIC FEET PER MINUTE) FOR PROPER APPLICATION.

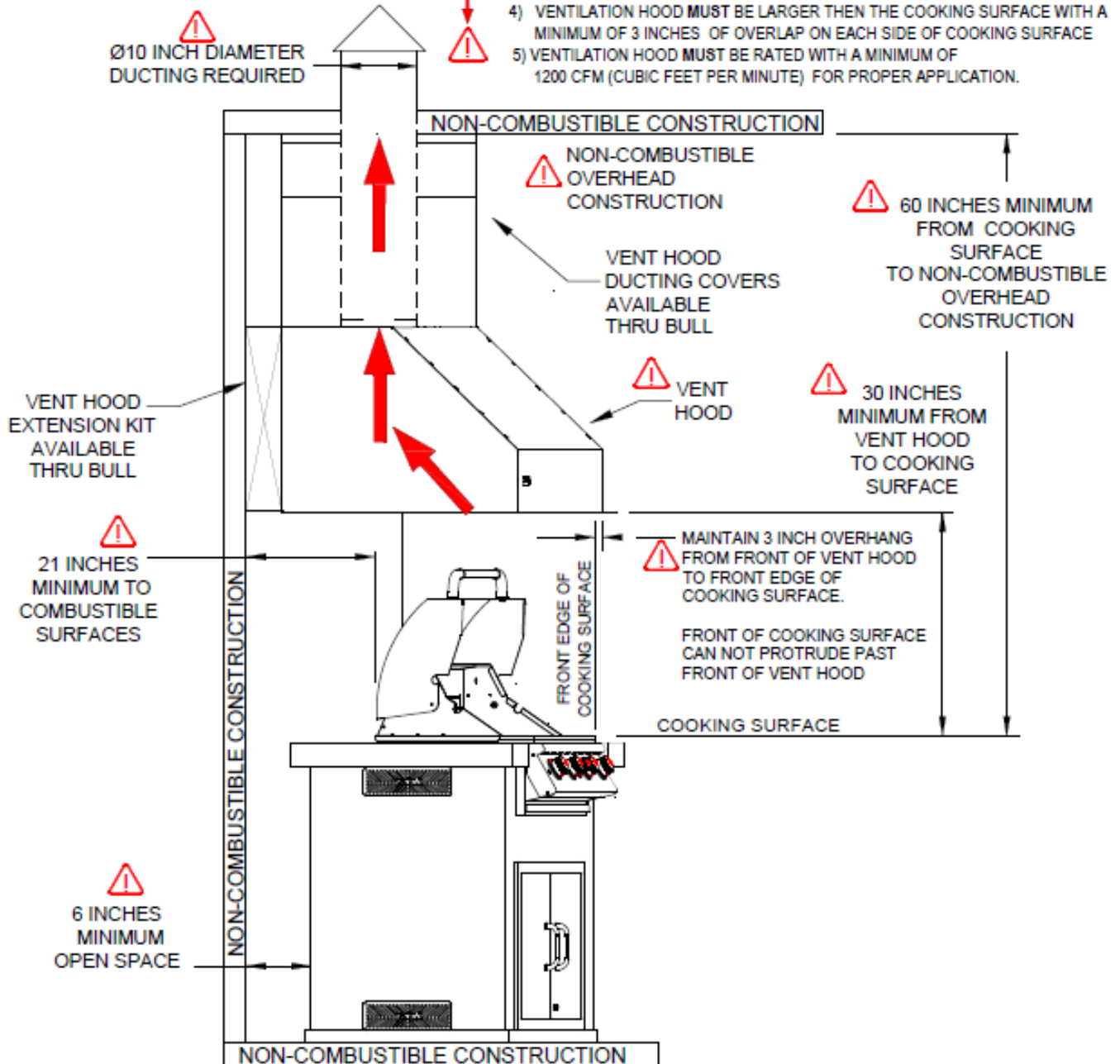



VENTILATION INSTRUCTIONS GRILL ENCLOSURES

Adequate enclosure ventilation is required to safely operate a Grill that is installed into an enclosure.

Please follow the instructions below, and applicable local codes.

We encourage using a professional for installing your grill into an enclosure.

QUANTITY OF VENTS

The enclosure must have four vents to remove combustion air produced by the Grill.

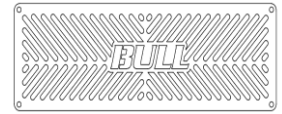

Your Bull dealer has enclosure vents made by Bull that meet industry standards to help.

If Bull vents are not used, please follow the guidelines and drawings below explain the details for the size and arrangement for these vents to meet your grill's ventilation needs. The four vents are required to be arranged in pairs. Each pair consists of an upper and lower vent.

VENT SIZE REQUIREMENTS:

The vents you use must meet ANSI Standard codes.

- I. **Upper Vents** must have openings that have a total free area of not less than 1 inch square per 1 lb. of stored fuel capacity per vent.
- II. **Lower Vents** must have openings that have a total free area of not less than 1/2-inch square per 1 lb. of stored fuel capacity per vent.
- III. **Both Upper and Lower Vent** openings must have minimum dimensions to permit the entrance of a 3/16-inch diameter rod.

VENT LOCATION OPTIONS WITH RESPECT TO ENCLOSURE:

Option 1

1) There should be 1 pair of vents installed on the center at each end of the enclosure per drawing below.

Option 2

2) There should be a pair vents installed on center with the grill on the enclosure wall behind the grill per drawing below.

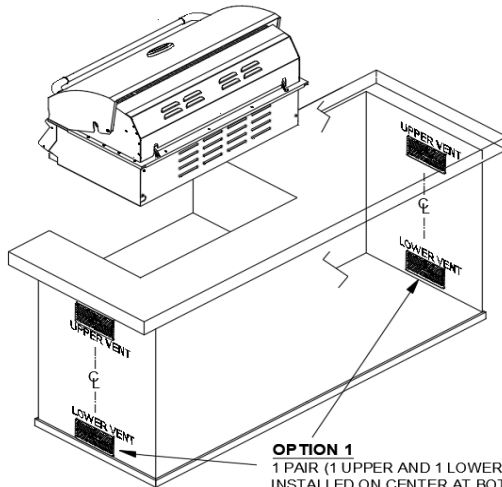

OPTION 1
1 PAIR (1 UPPER AND 1 LOWER VENT)
INSTALLED ON CENTER AT BOTH ENDS
OF ENCLOSURE.
(4 VENTS TOTAL)

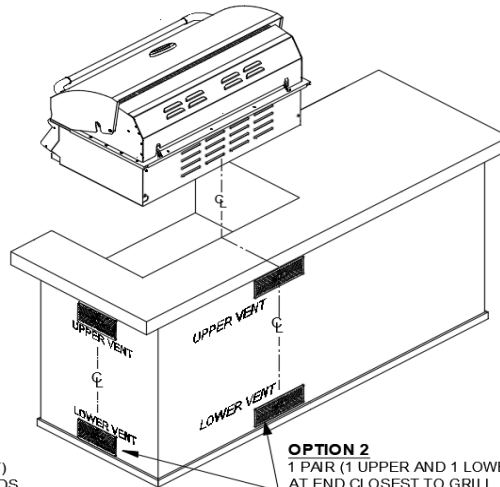

OPTION 2
1 PAIR (1 UPPER AND 1 LOWER VENT) INSTALLED
AT END CLOSEST TO GRILL.
AND
1 PAIR (1 UPPER AND 1 LOWER VENT) INSTALLED ON
CENTER BEHIND GRILL.
(4 VENTS TOTAL)

Per drawing below are the distances the vents need to be from the top and bottom of the grill's enclosure:

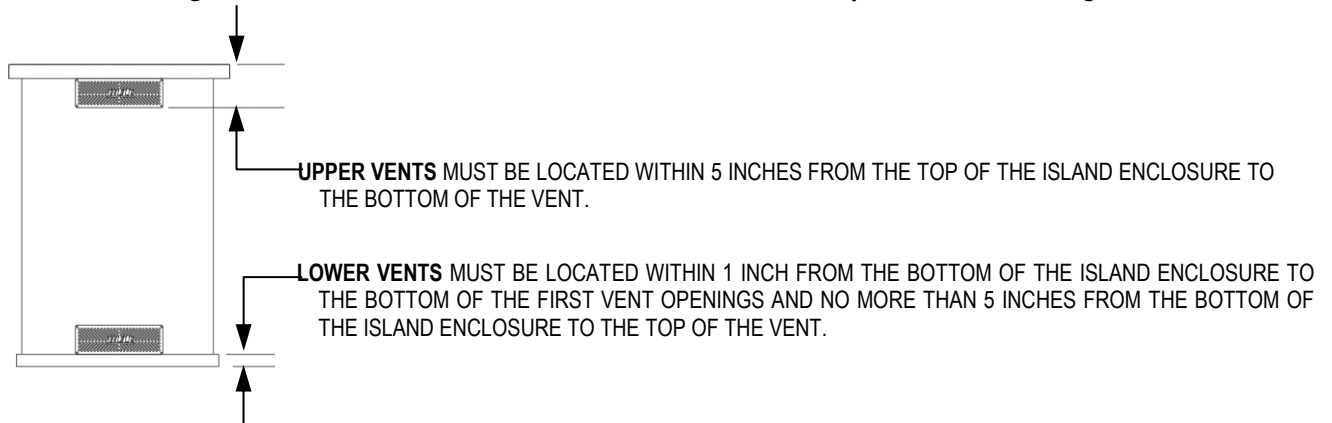

NOTE: ALL Vents must remain unobstructed to allow for combustion air and ventilation.



WARNING: IF THESE GUIDELINES ARE NOT FOLLOWED, FIRE CAUSING SERIOUS INJURY OR DEATH MAY OCCUR.



GUIDELINES FOR USING AN LP TANK IN AN ENCLOSURE



- 1) Per CSA, it is required that any built-in cabinet must have enough room for only 1 LP tank. The LP tank enclosure must not exceed (24.5" X 24.5" X 30") and there must be a minimum clearance of 2 inches between the floor and the propane tank enclosure.
- 2) Do not use any combustible materials for this construction.
- 3) There must be a minimum of 6 inches counter space behind the grill to allow the grill hood to clear properly.
- 4) The cylinder valve on the LP tank must be readily accessible for hand operation.
- 5) The LP tank must be isolated enough to where it is shielded from radiant heat and open flames.
- 6) The LP tank must be protected from foreign matter such as hot drippings.
- 7) There must be access so the LP tank can be connected, disconnected, inspected and leak tested outside of the enclosure.
- 8) The enclosure must provide access to allow leak testing of LP connections inside the enclosure for the LP Tank
- 9) The instructions shall indicate that the maximum length of the connection shall be 6 ft.
- 10) Please ensure visibility of the connector and directions for the piping, flexible tubing, and gas connector within enclosure.
- 11) The connector must comply with the Standard for Connectors for Outdoor Gas Appliances and Manufactured Homes, ANSI Z21.75 • CSA 6.27, and suitable for outside installation.
- 12) The LP gas supply cylinder(s) to be used must be constructed and marked in accordance with the Specifications for LP gas Cylinders of the U.S. Department of Transportation (D.O.T.) or the Standard for Cylinders, Spheres and Tubes for Transportation of Dangerous Goods and Commission, CAN/CSAB339, as applicable; and provided with a listed overfilling prevention device. And provided with a cylinder connection device compatible with the connection for outdoor cooking appliances.

LP TANK IS NOT SUPPLIED BY BULL.

- REFER TO NOTE 1 ON THIS PAGE FOR ENCLSURE SIZE REQUIREMENTS AND TO ALLOW ONLY 1 TANK IN AN ENCLOSURE.

WARNING:

- DO NOT STORE EMPTY OR FULL TANKS IN AN ENCLOSURE.
- DO NOT STORE AN EMPTY, SPARE OR DISCONNECTED LP GAS CYLINDER UNDER OR NEAR THIS GRILL OR ANY OTHER APPLIANCE.
- DO NOT USE A DENTED OR RUSTY LP GAS CYLINDER AS THIS MAY BE HAZARDOUS.

LP SUPPLY LINE DETAILS

NOTE: LP SUPPLY LINE FROM LP TANK TO GRILL CONNECTION MUST BE SECURED TO THE ENCLOSURE WALL THE BRACKET SHOWN IS FOR REFERENCE ONLY. MOUNTING HARDWARE (NOT SUPPLIED BY BULL)

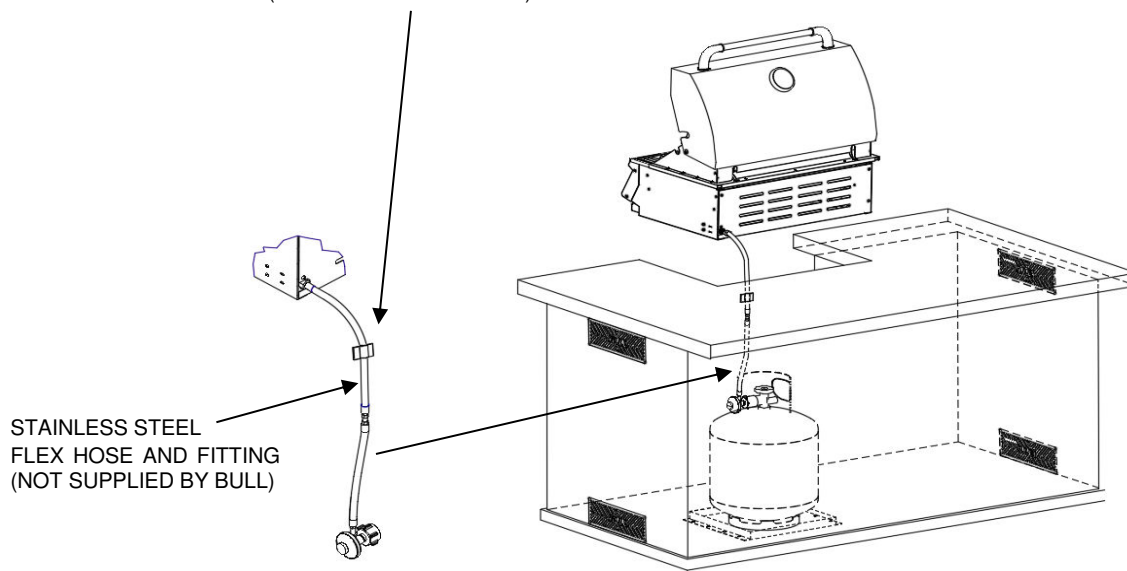



LP GAS TANK RETENTION GUIDELINES



NOTE: AN LP TANK (CYLINDER) WITHIN AN ENCLOSURE MUST USE A TANK RETENTION SYSTEM TO PREVENT BEING KNOCKED OVER. An LP Tank Retention System can be obtained through your Bull Dealer. Below are the requirements with supportive illustrations on how to install:



Any Tank Retention system must be securely fastened to the island floor using bolts with washers and nuts. There must be a minimum clearance of 2 inches between the floor and the cylinder enclosure. Once secured, place the LP tank in the tank retention system and tighten the tank retention bolts clockwise until the tank is held snug and cannot move. Turn the retention bolt counter clockwise to free the tank for removal.

WARNING: IF THESE GUIDELINES ARE NOT FOLLOWED, FIRE CAUSING SERIOUS INJURY OR DEATH MAY OCCUR.

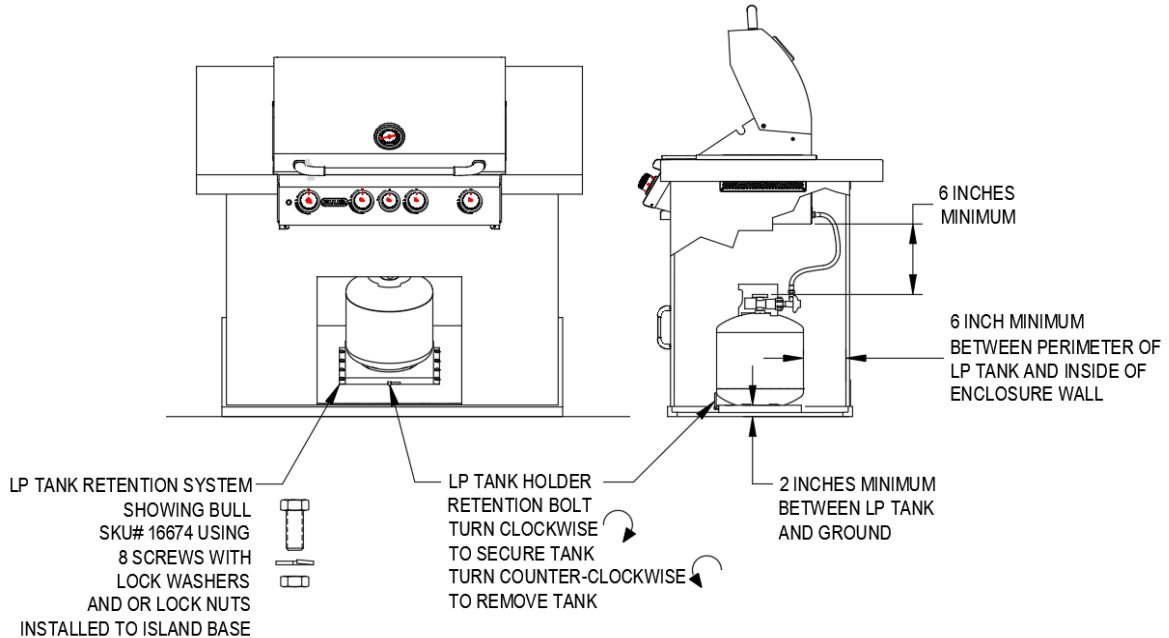

GRILL INSTALLATION INTO AN ENCLOSURE FOR LIQUID PROPANE OR NATURAL GAS GRILLS



Per illustration, the sides and back of the grill should not be any closer than **21 inches** to combustible construction.

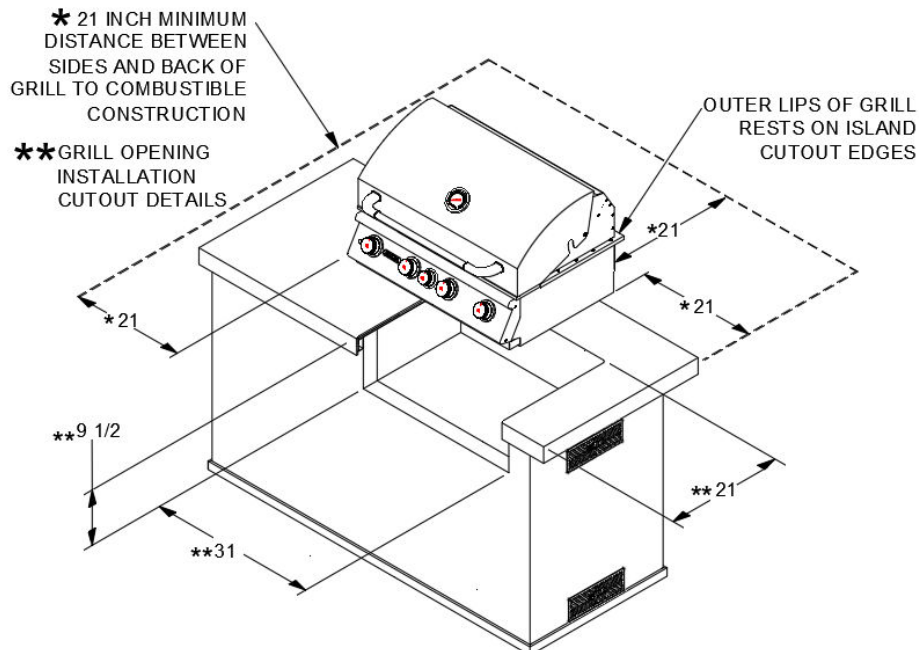

GRILL INSTALLATION DETAILS (DIMENSIONS ARE IN INCHES)



! IMPORTANT!

NATURAL GAS GRILL INSTALLATION SPECIFICATIONS

Refer to the following instructions and illustrations for typical gas supply connections.

We strongly suggest professional installation of your gas plumbing and connection to your grill.

IMPORTANT: Before connecting the grill to gas source, make sure grill control knobs are in "OFF" position.

Be sure to follow instructions for connecting an appliance to a fixed fuel piping system specifying the use of a rigid pipe, semi-rigid tubing, and/or a connector that complies with the Standard for Connectors for Outdoor Gas Appliances and Manufactured Homes, ANSI Z21.75 For post-mounted outdoor cooking gas appliances, in-ground metallic posts shall be protected against corrosion as warranted by soil conditions. A suitable coating of corrosion protection will retard the effects of corrosion and help your Bull purchase last longer.

IMPORTANT INSTALLATION GUIDELINES:

- 1) Vents must be provided for combustion air and ventilation on both sides of the built-in cabinet.
- 2) When choosing a location for your gas grill, keep in mind that it should never be located under any overhead combustible construction.
- 3) The sides and back of the grill should not be any closer than **21 inches** to combustible construction as shown in drawing below.
- 4) There must be a minimum of **6 inches** of counter space behind the grill to allow grill hood to clear properly.
- 5) Do not use any combustible materials for this construction.
- 6) Do not store empty or full spare gas tanks under or near this or any other appliance.

NATURAL GAS CONNECTION TO GRILL

IMPORTANT: Bull Outdoor Products does not recommend the use of any quick connection fittings or lines to the unit. The use of these types of fittings or lines could cause low gas flow and reduce the performance of the unit.

- 1) Do not use Teflon® tape or pipe sealant on any flare ends because you will not obtain a leak-free seal.
- 2) Remove plastic cap from regulator installed on grill.
- 3) Attach stainless steel flex line 3/8" flare-female end to the regulator.
- 4) Attach the other end of flex line to shut-off valve through a nipple.
- 5) Attach a shut-off valve to gas supply pipe.

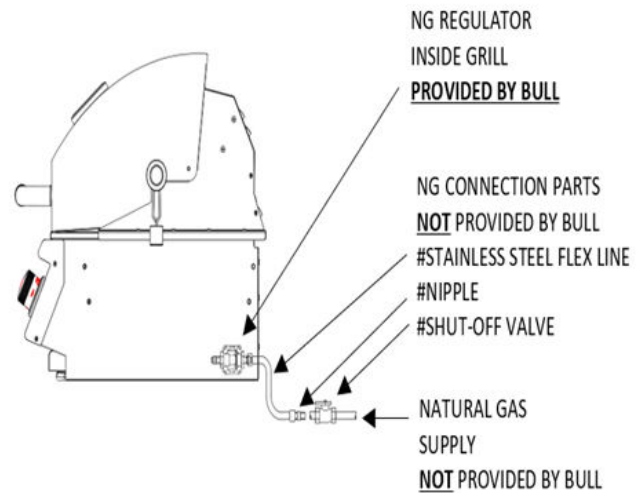

NATURAL GAS LINE SUPPLY LINE DETAILS

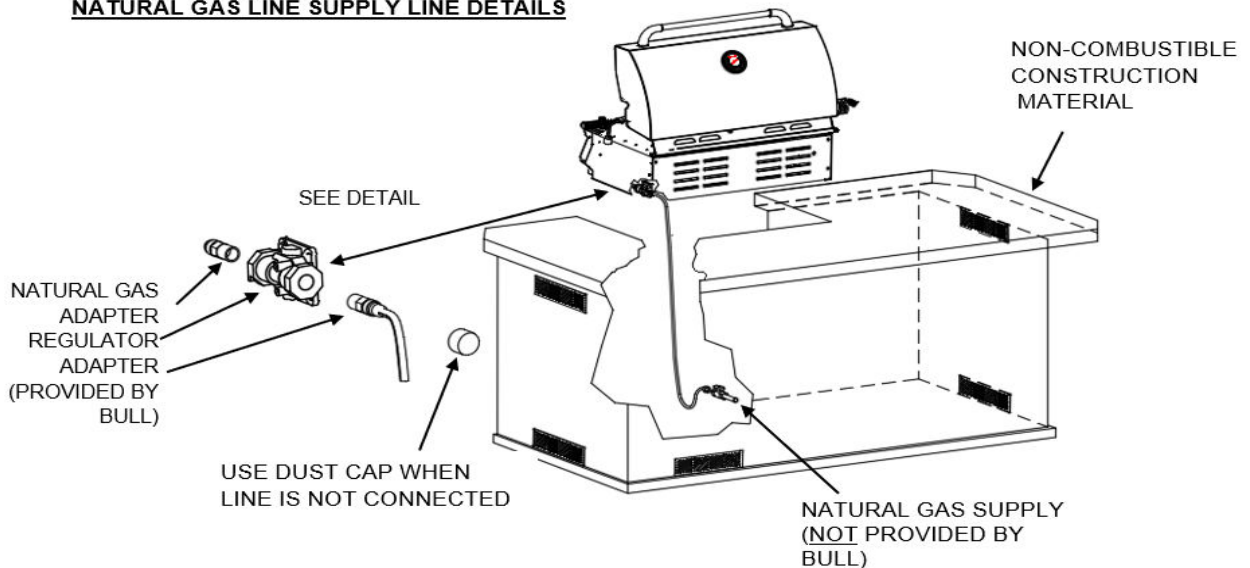

TO PERFORM GAS LEAK CHECK – REFER TO PAGE 3 OR 13



ANGUS GRILL LIGHT SYSTEM TRANSFORMER INSTALLATION

NOTE: Per illustration below, the transformer must be installed at least 6" above the ground to ensure longevity of the transformer and interior light system. The transformer has mounting holes so you can fasten to the frame inside your island or grill enclosure.

Fasteners are not provided to complete the installation of the transformer and the interior light system.

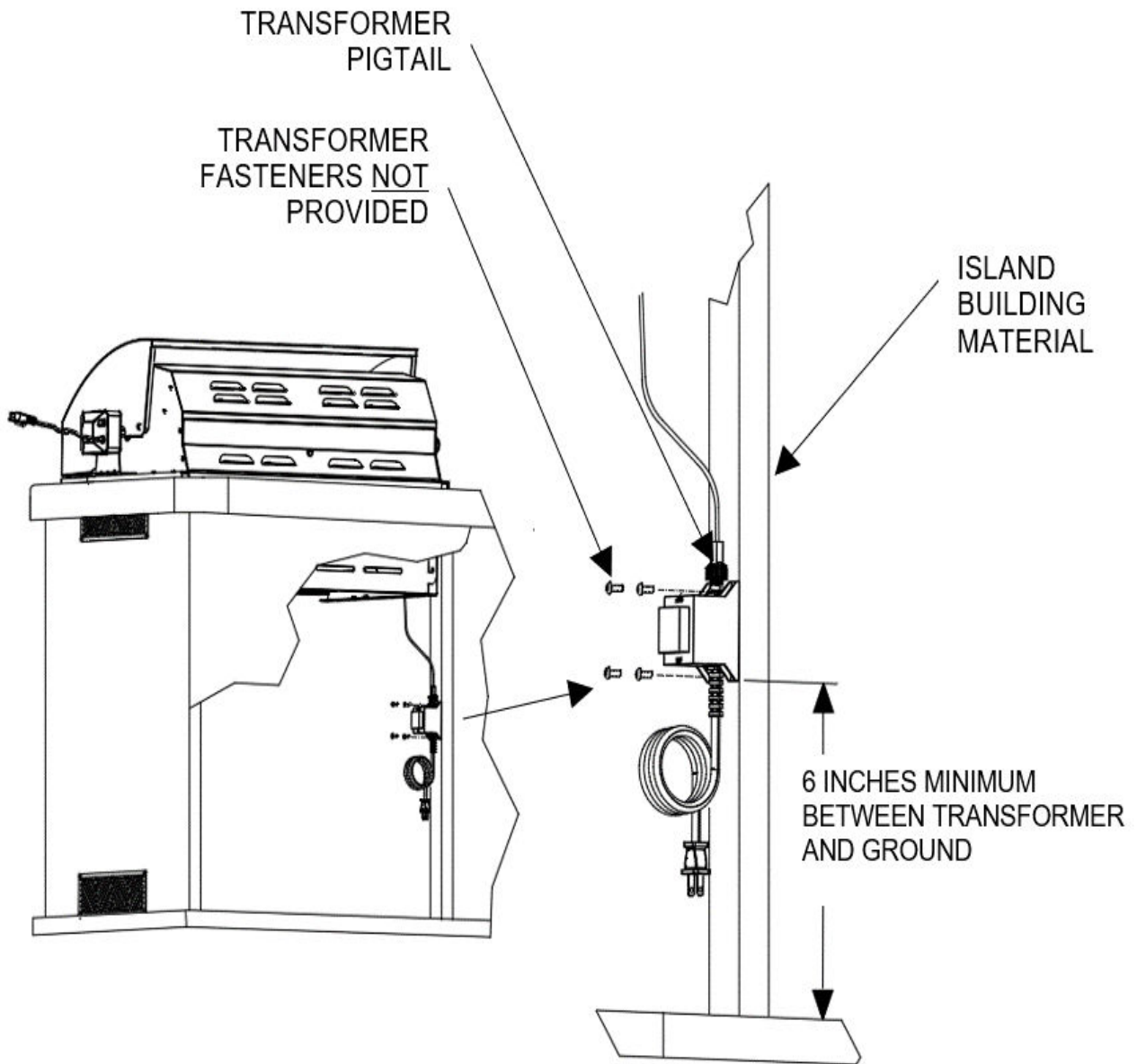



GRILL 'FIRST USE' LIGHTING PROCEDURE



- DO NOT SMOKE WHILE LIGHTING GRILL OR CHECKING GAS SUPPLY.
- CONNECTIONS BECOME FAMILIAR WITH THE SAFETY GUIDELINES AT THE FRONT OF THE MANUAL
- DO NOT LEAVE GRILL UNATTENDED DURING USE
- DO NOT MOVE GRILL DURING USE
- TURN OFF GAS SUPPLY AFTER USING GRILL
- IT IS RECOMMENDED YOU USE PROTECTIVE GLOVES TO OPERATE THE GRILL WHEN HANDLING ANY COMPONENTS WITH TRANSFERRED HEAT TEMPERATURE.

IMPORTANT! FOLLOW THE STEPS BELOW BEFORE FIRST USE OR AT START OF NEW GRILLING SEASON

- 1) If your grill fuel source is LP, check the gas cylinder to see if it's full.
- 2) Check that the end of each burner tube is properly located over each valve orifice.
- 3) Wash flame tamers, cooking grids, and warming rack with warm, soapy water.
- 4) Rinse and dry thoroughly.
- 5) Season metal surfaces with cooking oil and occasionally throughout the season.
- 6) **PERFORM LEAK TEST PER** instructions below to ensure that there are no gas leaks before first use, after changing gas tank or start of a new grilling season.
- 7) After cooking is completed, turn grill to high setting for NO MORE THAN five minutes to burn off excess grease or food residue.

LEAK CHECK INSTRUCTIONS

- 1) Turn off heat control valve(s), and then turn on gas at source.
- 2) Make a soap solution by mixing one-part liquid detergent and one-part water.
- 3) Apply the soap solution to all gas connections: bubbles will appear in the soap solution if connections are not properly sealed. Tighten or repair, as necessary.
- 4) If you have a gas leak that you cannot repair, turn off the gas at the source, disconnect the fuel line from the grill and immediately call your grill dealer and gas supplier for professional assistance.
- 5) **Make sure all gas connections are securely tightened.**

FIRST USE OR FIRST USE 'BURN OFF' GUIDELINES:

Always open the lid before lighting. Do not move the appliance when it is in use.

NOTE: The gas lines and burners will be full of air after assembly or installation. Before lighting, please follow the steps below to purge the gas lines and prime them with gas to properly ignite the burners on your grill. It may require several attempts at lighting the burners before you are successful.

- 1) With Grill control knobs in "OFF" position, turn on the Gas supply.
- 2) Light any burner by pushing its control knob in fully and slowly (3 to 4 seconds) turning it about 1/4 turn to the left (counterclockwise) until a click is heard. The 3 to 4 second duration should provide enough gas to light the burner. If the burner does not light, immediately return the control knob to "OFF," wait 5 minutes for the gas to disperse, and repeat the process. After burner lights successfully, turn control knob to "OFF."
- 3) Repeat process for each control knob/igniter, in turn, ensuring that other knobs are in "OFF" position as you perform each check.
- 4) You will need to perform a 'burn off' to the grill to get rid of any odors or foreign matter by igniting the burners, closing the lid, and operating at "HIGH" setting for about five minutes. **NOTE:** Seasoning your grill is optional if you do use with cooking oil.
- 5) If any burners fail to light after several attempts, discontinue the gas supply at source and re-inspect for obstructions to gas flow and orifices.

NOTE: TO LIGHT INFRARED BURNER, TURN KNOB AND WAIT ABOUT 10 SECONDS TO ALLOW GAS TO GET TO BURNER BEFORE CLICKING IGNITION KNOB.

ALWAYS LIGHT THE GRILL WITH THE LID IN AN OPEN POSITION!

WARNING: IF THESE GUIDELINES ARE NOT FOLLOWED, FIRE CAUSING SERIOUS INJURY OR DEATH MAY OCCUR.



GRILL STANDARD LIGHTING PROCEDURE



DO NOT SMOKE WHILE LIGHTING GRILL OR CHECKING GAS SUPPLY CONNECTIONS!



Set ALL Grill control knobs to "OFF."
and open gas supply, LP cylinder or Natural Gas Valve.

LIGHTING MAIN BURNER(S):

- 1) Become familiar with the safety guidelines at the front of the manual.
- 2) If your grill fuel source is an LP gas cylinder, check to see that cylinder is filled.
- 3) Check that the end of each burner tube is properly located over each valve orifice.
- 4) Make sure all gas connections are securely tightened.

TEST FOR LEAKS WITH A SOAP SOLUTION, NEVER WITH A FLAME.

(Gas Leak Check instructions are on pages 3 & 13)

5) **Always open the lid before lighting.**

6) Set ALL Grill control knobs to "OFF" and open gas supply, LP cylinder or at Natural Gas Valve.

7) Ignite only the burners you intend to use, using the same method for each: Push in control knob completely and rotate slowly (3 to 4 seconds) about 1/4 turn to the left counterclockwise until a click is heard. The 3 to 4 second duration should provide enough gas to light the burner. If the burner does not light, immediately return the control knob to 'OFF,' wait 5 minutes for the gas to disperse, and repeat the process. After the burner ignites, repeat procedure with any other burner needed.

8) Adjust control knob(s) to desired cooking temperature.

NOTE: Initially, the Burner will have a blue flame (see illustration guideline below). After some time, the color of the flame will be orange.

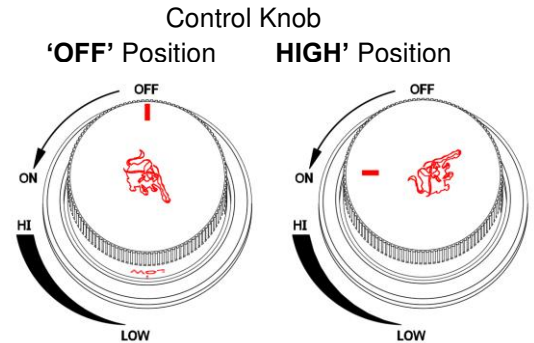

If the burner does not light after several attempts, immediately (or within 5 seconds) return the control knob to 'OFF', wait 5 minutes for the gas to disperse before repeating the process or attempting to manually light the grill per instructions shown below.

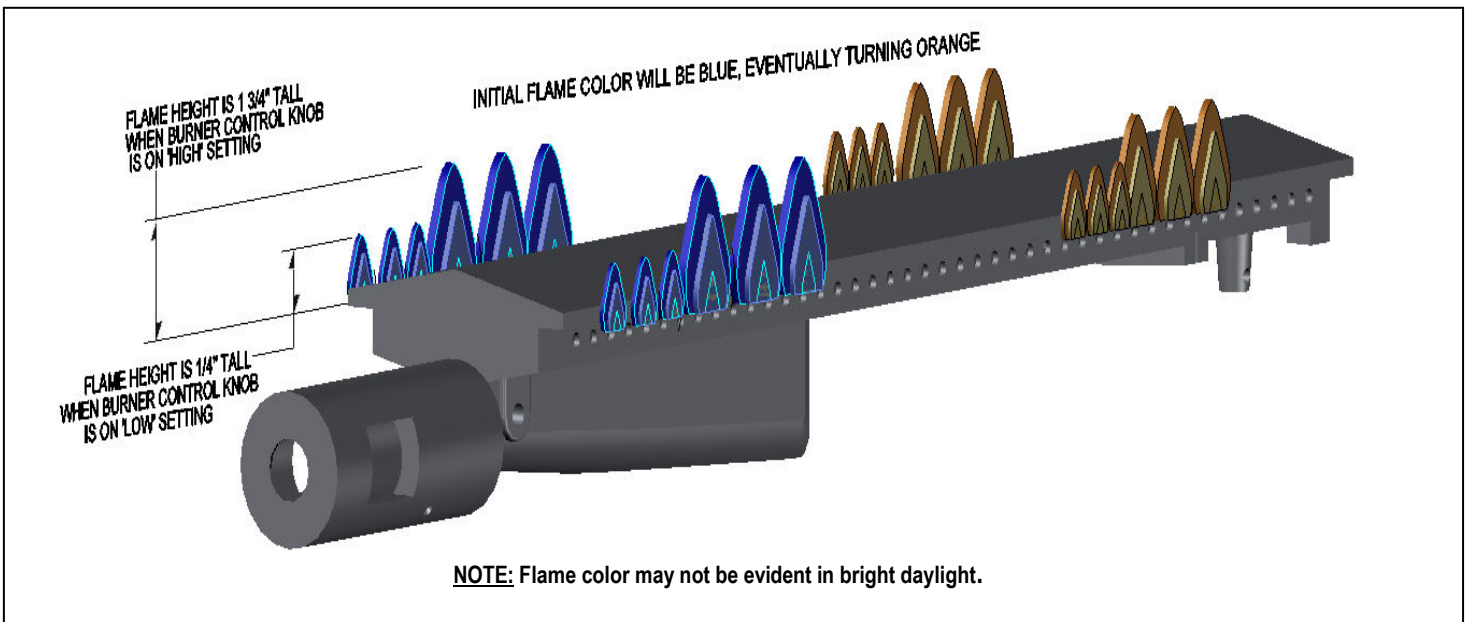

9) **NOTE:** If igniters fail to produce a spark at the electrode tip, burners can be manually ignited with a fireplace-type match. See the next page for instructions.

WARNING: IF THESE GUIDELINES ARE NOT FOLLOWED, FIRE CAUSING SERIOUS INJURY OR DEATH MAY OCCUR.



TO LIGHT GRILL WITH A FIREPLACE-TYPE MATCH

NOTE: To light gas grill with a fireplace-type match,

- 1) Use provided Lighting Rod to hold a lighted fireplace type match or long-necked butane lighter placing flame near to burner ports.
- 2) Push in control knob completely and rotate slowly (3 to 4 seconds) about 1/4 turn to the left counter clockwise until a click is heard. The 3 to 4 second duration should supply enough gas to light the burner. If the burner does not light, immediately return the control knob to 'OFF' position, and wait 5 minutes for the gas to disperse, and repeat the process.
- 3) Turn off burners that are not needed and adjust other burners to desired cooking temperature.

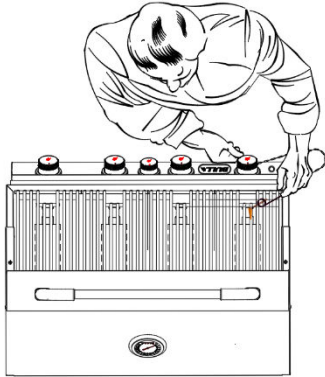

The provided Lighting Rod is for holding a fireplace match to light the grill. Is located inside the front of the grease tray as shown below.

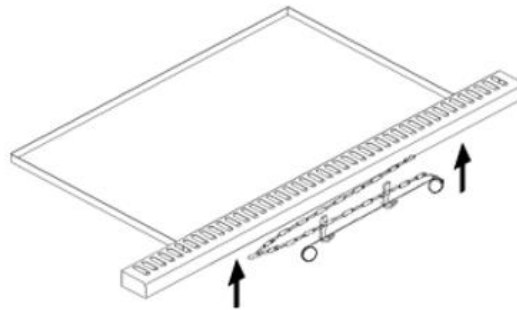

INFRARED "BACK BURNER" The rear infrared back burner allows for slow roisserie cooking of meats and poultry. Infrared burners radiate heat onto the outer surface of the food. This allows cooking without the grease drippings burning on the flame tamers.

INFRARED "BACK BURNER" SAFETY GUIDELINES

WARNING: ALWAYS LIGHT THE GRILL WITH THE HOOD IN AN OPEN POSITION!

- THE 'BACK BURNER CONTROL KNOB HAS A FIXED SETTING AND IS NOT ADJUSTABLE. DO NOT ATTEMPT TO REGULATE THE BACK BURNER BY USING THE CONTROL KNOB.
- NEVER OPERATE ROTISSERIE BURNER WITH MAIN BURNER(S) "ON"
- WARMING RACK MUST BE REMOVED WHEN OPERATING THE ROTISSERIE BURNER

INFRARED "BACK BURNER" LIGHTING INSTRUCTIONS:

- 1) Set ALL Grill control knobs to "OFF" and open gas supply, LP cylinder or Natural Gas Valve.
- 2) The Back Burner is the smaller control knob found in the middle of the Control Panel. Push in control knob completely and rotate slowly (5 to 10 seconds) about 1/4 turn to the left counterclockwise until a click is heard. The 5 to 10 second duration should provide enough gas to light the burner. If the burner does not light, immediately return the control knob to "OFF," wait 5 minutes for any accumulated gas to clear out of the grill.
- 3) After lighting, keep lid closed and operate 'Back Burner' at the "ON" position when using rotisserie.

TO LIGHT INFRARED BURNER WITH A FIREPLACE-TYPE MATCH

1) Follow steps 1 & 2 above. Carefully insert lighted fireplace-type match or long-necked butane lighter placing flame near to the Ceramic Panel. Press the control knob and rotate left counterclockwise to "HIGH" or "ON" setting to release gas. Burner should light immediately. After lighting keep lid closed when using rotisserie.

2) **NOTE:** Rotisserie burner may take a few attempts to ignite.

WARNING: IF THESE GUIDELINES ARE NOT FOLLOWED, FIRE CAUSING SERIOUS INJURY OR DEATH MAY OCCUR.



COOKING COMPONENT INSTALLATION, CAUTION, BEFORE YOU START:

- 1) Turn off the gas supply at the gas supply source first.
- 2) It is recommended you use protective gloves while operating the grill or when handling any components with transferred heat temperature.
- 3) Do not move the grill during use.
- 4) Check gas valve orifices, burner tubes and burner ports for any obstructions.

PER DRAWING BELOW:

- 5) Place stainless steel heat shields on lowest ledge under/between burners in grill insert.
- 6) Place stainless steel flame tamers on the lower ledge above burners in grill insert.
- 7) Place cooking grates in grill insert on ledge above flame tamers.
- 8) Please read Safety, Lighting and Operating Instructions carefully.

For more help installing components, go to <https://bullbbq.com/bull-support-videos/>

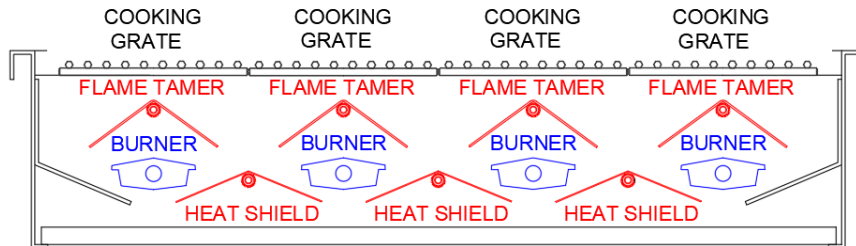

NOW YOUR GAS GRILL IS READY TO USE!

ANY MODIFICATION OF THE APPLIANCE MAY BE DANGEROUS TO YOU OR OTHERS AND MAY VOID PRODUCT WARRANTY

COOKING TEMPERATURE SETTINGS

HIGH SETTING Use this setting only for fast warm-up, for searing steaks and chops, and for burning food residue from the cooking grids after the cookout is over.

MEDIUM SETTING Use this setting for most grilling, roasting or baking, and for cooking hamburgers and vegetables.

LOW SETTING Use this setting for all smoke cooking, rotisserie cooking, and when cooking very lean cuts such as fish.

NOTE: These temperatures vary with the outside temperature and the amount of wind.

PREHEATING: It is necessary to preheat the grill briefly before cooking certain foods, depending on the type of food and the cooking temperature. Food that requires a high cooking temperature will need to preheat for five minutes; food that requires a lower cooking temperature needs only two to three minutes. There is no need to preheat for casseroles or other foods that require slow cooking.

COOKING METHODS

You can cook poultry and large cuts of meat slowly to perfection on one side of the grill by indirect heat from the next burner or with infrared rotisserie burner. The heat from the lighted burner circulates gently throughout the grill, cooking the meat or poultry without any direct flame beneath or below the food you are preparing. This method reduces flare-ups when cooking extra fatty cuts, because there is no direct flame to ignite the fats and juices that drip down during cooking. Place a drip pan slightly smaller than the cut of meat on the cooking grids or flame tamer surface under the meat. This will allow you to catch meat juices for making gravy.

FLARE-UPS:

The fats and juices that drip from the meat cause flare-ups. Since flare-ups impart the distinctive taste and color to food cooked over an open flame, should be expected, and encouraged within reason.

CAUTION: Uncontrolled flaring can result in a ruined meal. To control excessive flare-ups caused by too high a heat setting, turn the heat control knob to a lower setting.

CAUTION: If burners go out during operation, close the gas supply at source, and turn all gas valves off. Open lid and wait five minutes before trying to re-light (this allows accumulated gas fumes to clear).

CAUTION: Should a grease fire occur, close the gas supply at source, turn off all burners and leave lid closed until fire is out. Do not use water or any liquid to extinguish a grease fire.

CAUTION: Do not attempt to disconnect any gas fitting while your grill is in operation or while gas feed is on.



ROTISSERIE SYSTEM INSTALLATION TO ANGUS GRILL

- 1) The trolley thumb screw should be located on the inside of the grill; screw the knurled nut on next, add the counterweight followed by screw on the black handle.
- 2) **SETTING THE COUNTERWEIGHT**, the purpose of the counterweight is to balance the rotation and prevent lopsided movement of the motor. To adjust the counterweight, loosen the black handle and slide the counterweight up or down to properly position the weight of the food.

3) ROTISSERIE SYSTEM OPERATION

NOTE: FOLLOWING THE GUIDELINES BELOW WILL PREVENT STRAINING YOUR ROTISSERIE SPIT ROD AND MOTOR

- 1) **DO NOT EXCEED 20 lb. MAX WEIGHT CAPACITY**
- 2) **THE ITEM YOUR PREPARING NEEDS TO BE PLACED IN A BALANCED POSITION ON THE ROTISSERIE SPIT ROD.**
- 3) **BEFORE LIGHTING THE INFRARED BURNER CHECK TO MAKE SURE THE MEAT DOES NOT HIT THE INFRARED BURNER WHILE TURNING.**

WARNING:!

- **NEVER OPERATE ROTISSERIE BURNER WITH MAIN BURNER(S) "ON"**
- **WARMING RACK MUST BE REMOVED WHEN OPERATING THE ROTISSERIE BURNER**

ALWAYS LIGHT THE GRILL WITH THE HOOD IN AN OPEN POSITION!

ROTISSERIE COOKING OPTIONS (ANGUS GRILL)

Rotisserie is a great method for cooking meat or poultry pieces slowly and evenly. The constant turning provides a self-basting action, making food cooked on a rotisserie exceptionally moist and juicy. Rotisserie cooking requires 1 ½ to 4 ½ hrs. depending on the size and type of meat being cooked.

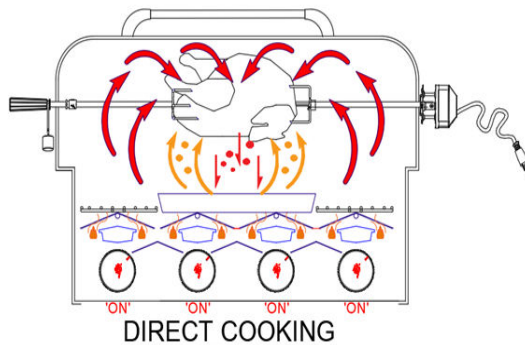

DIRECT COOKING

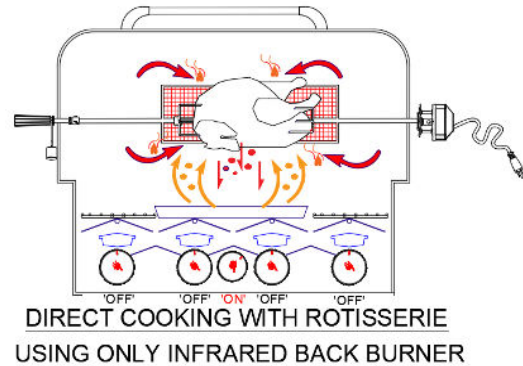

**DIRECT COOKING WITH ROTISSERIE
USING ONLY INFRARED BACK BURNER**

ROTISSERIE COOKING WITH INDIRECT HEAT

Indirect heat can be used cooking on a rotisserie but remember to use foil or an aluminium drip pan to prevent excessive flare-ups. Before you start, remove the cooking grates to allow use of a basting pan under the rotisserie area on top of the flame tamer(s) to catch the drippings. Lastly, rotate the meat on the spit rod to make sure it clears everything.

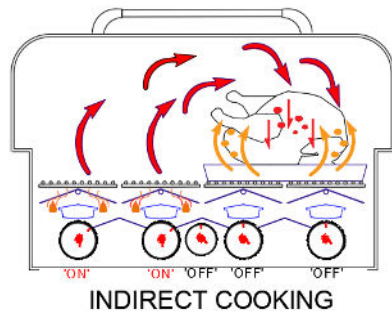

INDIRECT COOKING

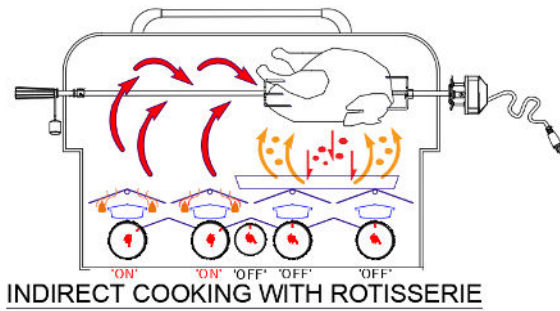

INDIRECT COOKING WITH ROTISSERIE



REMOVAL OF COTTER PINS USED TO RETAIN BURNERS

Your grill has four cast stainless-steel burners. Each burner has a cotter pin to keep them in place during shipping. You will need to remove the cotter pins to allow burner removal for inspection and or cleaning. The cotter pins can be discarded or retained in case the grill is relocated.

Please follow these safety instructions below, we also have a helpful video at <https://bullbbq.com/bull-support-videos/>
Suggested tools: Needle Nose Pliers / Flashlight

SAFETY INSTRUCTIONS PRIOR TO REMOVAL OF COTTER PINS USED TO RETAIN BURNERS



If your grill has been used, or has the gas supply already installed, always follow these safety instructions first.

If you have never used your grill, or have not installed it, you'll need to take it out of the shipping box. Position the grill so you can see and reach inside the area under the grill inside of the back panel. To access the cotter pins, you will need to remove the grease tray and proceed to step 7

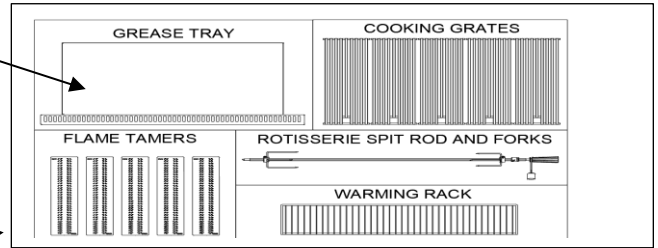

Always follow these instructions below prior to burner removal:

- 1) Do not attempt during or right after use.
- 2) Allow grill to cool long enough to touch inside.
- 3) Always turn off the gas supply prior to cleaning your grill.
- 4) Gas control knobs should be in the "OFF" position.
- 5) Remove these items from the grill.
- 6) Disconnect the flexible fuel line from the gas valve manifold. The fuel line is behind the right side of the control panel and can be accessed from underneath the grill.

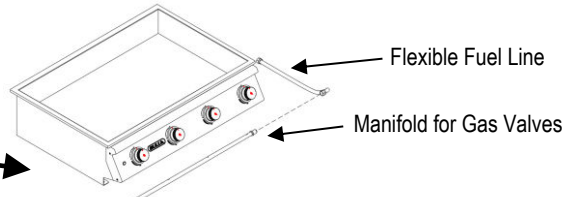

- 7) Next, go to the back side of the grill and look underneath the inside of the back panel at the spot where you pull out the grease tray. Each burner has a post and cotter pin on the underside of the burner facing the back end of the grill. The cotter pin holds the burner post in the hole on the grill during shipping. Per detail, use your pliers to pull the cotter pin out of the burner post allowing you to lift the burner from the grill. The cotter pins can be discarded or retained in case the grill is shipped again.

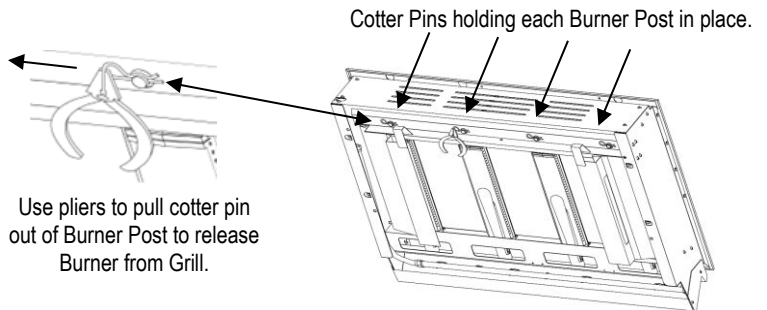

Now you're ready to remove the Burners

INSTRUCTIONS FOR REMOVAL OF BURNERS

FOLLOW STEPS 1 THROUGH 6

- 8) Lift the burner out of the retaining hole and slide the burner free from the gas valve tip as shown below. To re-install burners, slide burner back onto gas valve tip far enough to allow the burner retainer post to go into retaining hole.

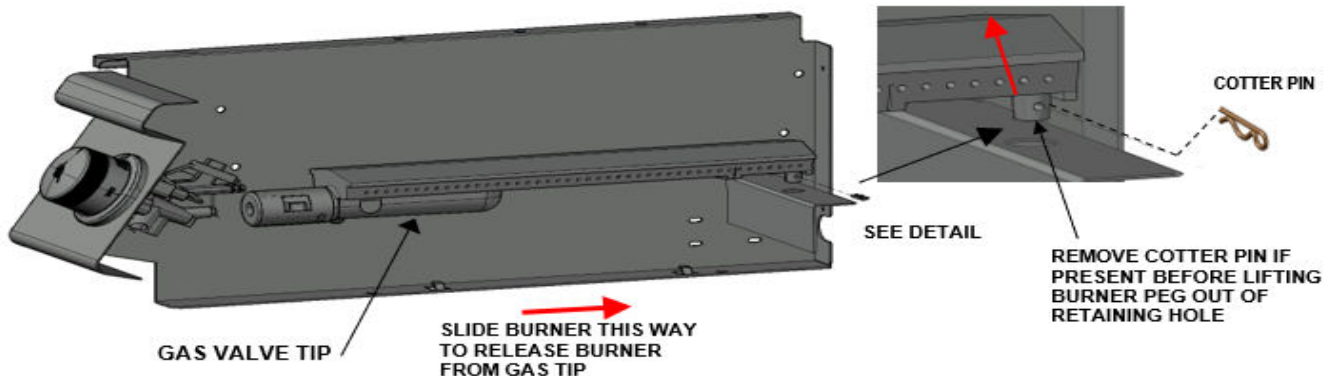



BURNER INSPECTION AND CLEANING

This procedure should be followed at least once a month or when your grill has not been used for an extended period. Performing this task reduces the chance of 'FLASHBACK' from occurring.

For safety, always follow BURNER REMOVAL INSTRUCTION ON PAGE 18

MONTHLY BURNER INSPECTION INSTRUCTIONS

After burners are removed:

- 1) First check the following areas shown below to verify they are damage free and clear of debris.
- 2) Monthly inspection of the burners for damage (cracks or holes) or any openings caused by corrosion. If such damage is found, order and install a new burner.
- 3) After installation, check to ensure the gas valve orifices are correctly placed inside ends of burner tubes.
- 4) Be sure to follow the cleaning instructions after inspection.

Verify that the Burner Tube and all Burner Ports are clear of debris.

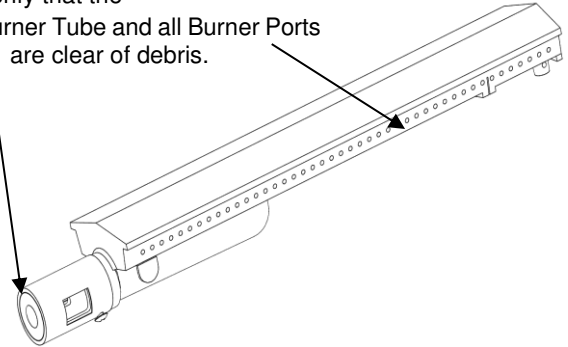

BURNER CLEANING INSTRUCTIONS

Suggested Cleaning Tools:

Bottlebrush, Wire Brush, Paper Clip

- 1) Use a narrow bottlebrush with a flexible handle to clean burner tube and inside of burner.

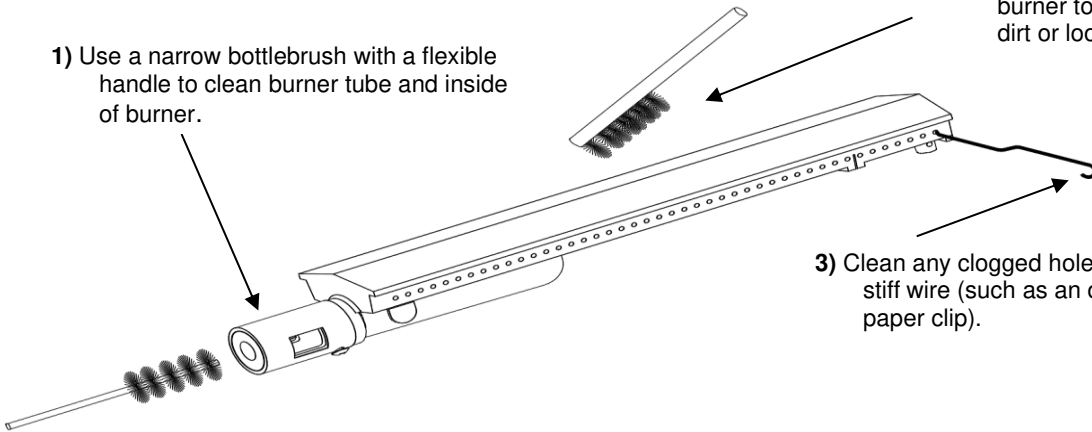

- 2) Wire brush entire outer surface of burner to remove food residue, dirt or loose corrosion.

- 3) Clean any clogged hole with a stiff wire (such as an open paper clip).

BURNER SHUTTER CLIP INSPECTION / ADJUSTMENT

The burners are pre-set by the factory, however the air to fuel mixture may need to be adjusted to accommodate different gas pressures. To adjust the air to fuel mixture, loosen the screw and rotate the shutter clip to the appropriate setting (see illustration) Tighten the screw and repeat adjustment procedure on the remaining burners.

Shutter Clip Shown in 'OPEN' Position for LIQUID PROPANE

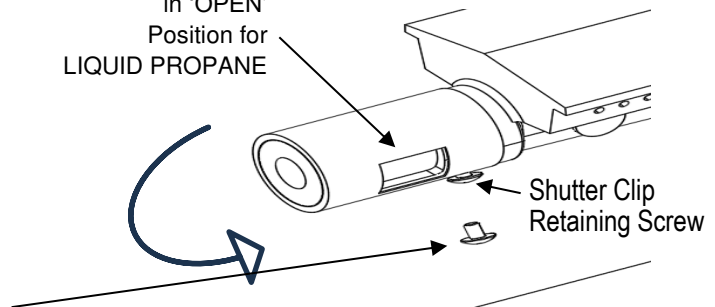

Shutter Clip Shown in 'CLOSED' Position for NATURAL GAS

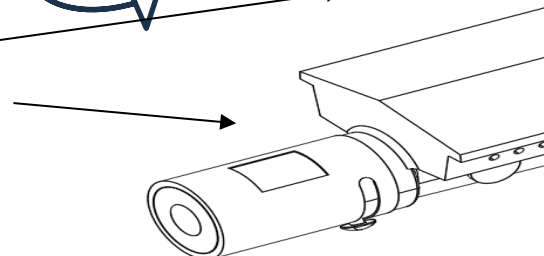



INSERTING BURNER INTO GRILL

CAUTION- ALWAYS TURN OFF GAS SUPPLY PRIOR



INSTALLING BURNERS BACK IN GRILL

Note, there is no need to use the cotter pin while installing the back into position. It is for shipping purposes only.

IMPORTANT NOTE Check the burner to make sure it is properly located after replacing.

Make sure the valve orifices are inside the burner tubes (see illustration below).

WARNING If the valve orifices do not fit inside the burner tubes, lighting the burners may cause an explosion and/or fire.

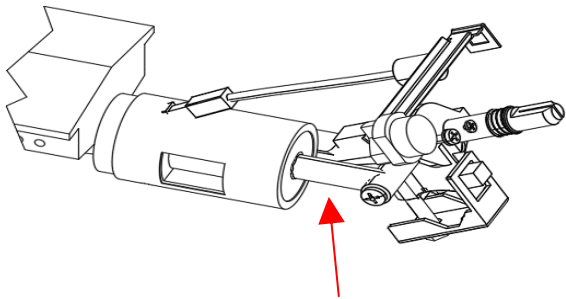

CORRECT POSITION

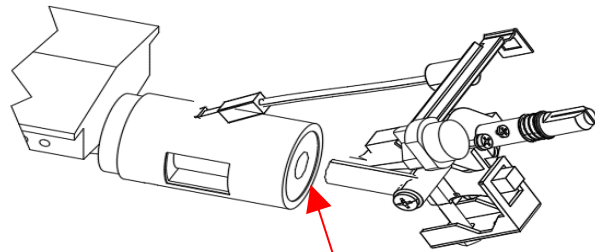

**INCORRECT POSITION
NOTE GAP BETWEEN BURNER TUBE
AND BURNER ORIFICE**

BURNER IGNITOR / ELECTRODE INSPECTION

With all control knobs set to "OFF," in turn, push each control knob in fully and turn slowly about a 1/4 turn to the left (counterclockwise) until a click is heard and you should see a blue spark at the electrode tip. If you do not see a spark, refer to page 22 for troubleshooting. Return control knob to "OFF" before checking the next igniter.

BURNER OPERATION CHECK

- 1) With Grill control knobs in "OFF" position, turn on the Gas supply.
- 2) Light any burner by pushing its control knob fully and slowly (3 to 4 seconds) turning it about 1/4 turn to the left (counterclockwise) until a click is heard. The 3 to 4 second duration should provide enough gas to light the burner. If the burner does not light, immediately return the control knob to "OFF," wait 5 minutes for the gas to disperse, and repeat the process. After burner lights successfully, turn control knob to "OFF."
- 3) Repeat process for each control knob/igniter, in turn, ensuring that other knobs are in "OFF" position as you perform each check.

If any burners fail to light after several attempts, discontinue gas supply at source and re-inspect for obstructions to gas flow and orifices.

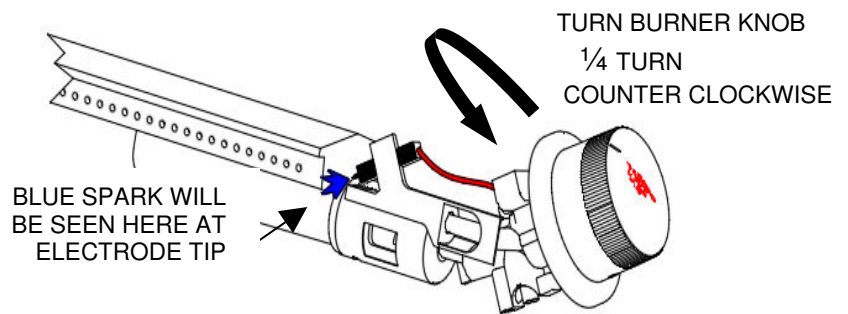

**BLUE SPARK WILL
BE SEEN HERE AT
ELECTRODE TIP**

**TURN BURNER KNOB
1/4 TURN
COUNTER CLOCKWISE**

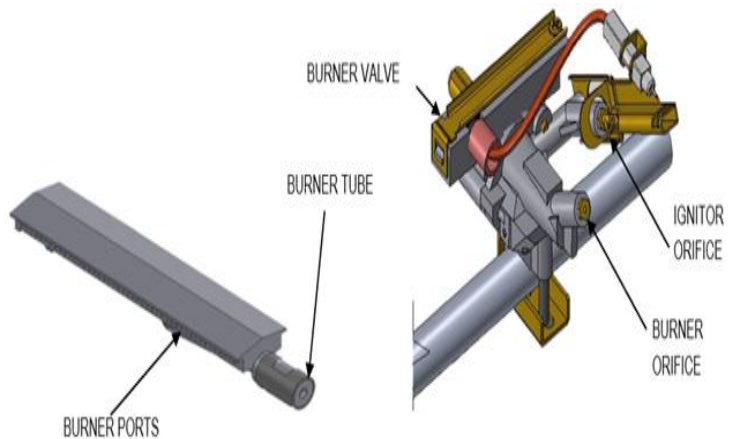



GRILL LIGHTING SYSTEM LIGHT BULB REPLACEMENT INSTRUCTIONS

1) Remove screw with a small Phillips screwdriver. Caution: Glass cover may be loose, ensure the cover supported before completely removing the screw.

2) There is a metal clip that clamps onto the glass cover and snaps into the light housing on the screw end. Unsnap the cover by carefully prying apart the metal clip from the light bulb housing. Once unsnapped, slide the cover out and away from the housing and set somewhere safe.

3) Remove old light bulb by pulling the bulb out of the housing (make sure bulb is cool before removal)

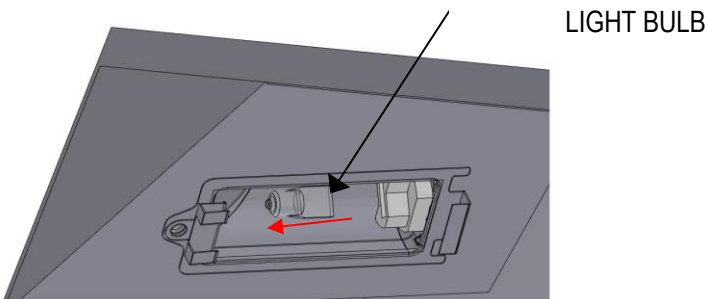
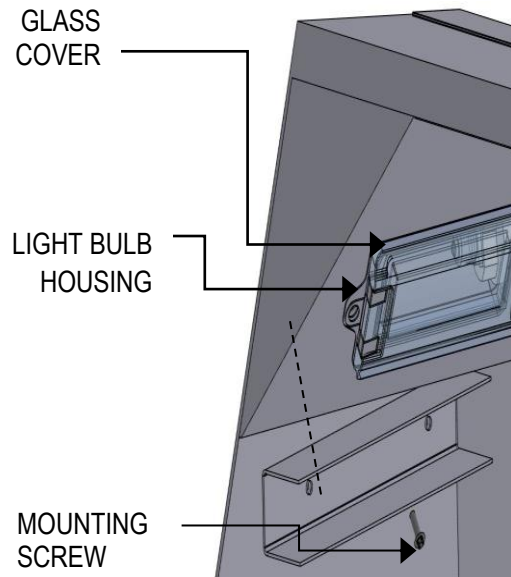

4) Using a soft cloth or paper towel, replace new light bulb in the housing (fingerprints left on the bulb may reduce its life). Make sure the metal prongs on the light bulb slip into the openings in the light housing.

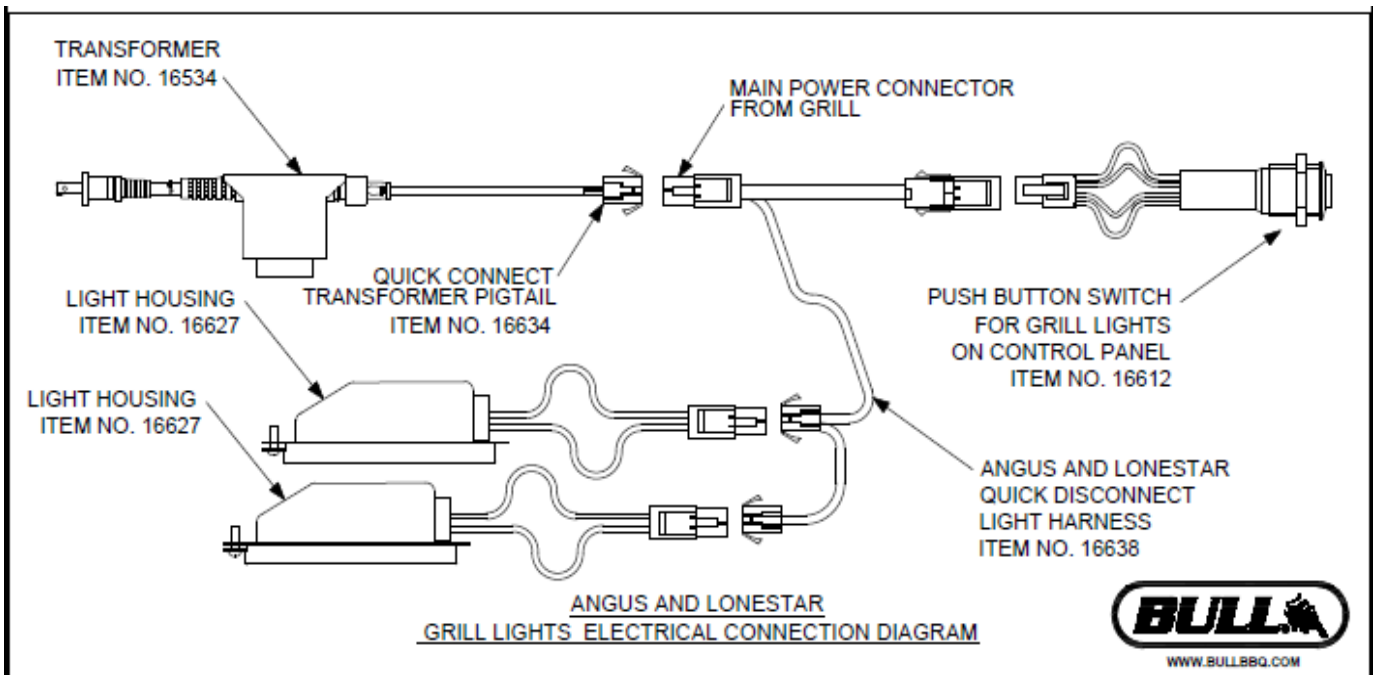
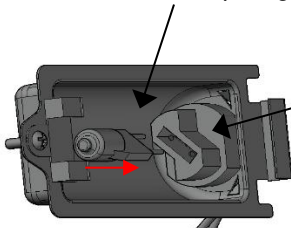



ANNUAL CLEANING & MAINTENANCE

- (1) Keeping outdoor cooking gas appliance area clear and free from combustible materials, gasoline, flammable vapors, and flammable liquids.
- (2) Not obstructing the flow of combustion and ventilation air.
- (3) Keeping the ventilation opening(s) of the cylinder enclosure free and clear from debris.
Visually checking burner flames including pilot burner flame if provided, with pictorial representations.

CLEANING THE COOKING GRATES:

After cooking, turn control knobs to "OFF" and let grill cool before attempting to clean your cooking grids. Before first use and periodically it is suggested that you wash the cooking grids in a mild soap and warm water solution. You can use a washcloth or a vegetable brush to clean your cooking grids.

CLEANING THE FLAME TAMERS & HEAT SHIELDS

Washing the flame tamers & heat shields after every use is not necessary but periodically it is suggested you wash them in a soap and warm water solution. Use a wire brush to remove stubborn cooking residue. Dry the flame tamers & heat shields thoroughly before you reinstall it in the cooking insert.

CLEANING THE GREASE TRAY

The grease tray should be emptied and wiped down periodically and washed in a mild detergent and warm water solution.

ANNUAL CLEANING OF GRILL HOUSING

Burning-off the grill after every cookout will keep it ready for instant use. However, periodically the grill should be cleaned thoroughly to ensure optimal performance.

- 1) Shut off gas supply at source and disconnect fuel line from gas valve manifold. Protect fuel line fitting.
- 2) Remove and clean (as explained above) the cooking grids, flame tamers and burners.
- 3) Remove warming rack and wash with mild detergent and warm water.
- 4) Cover the gas valve orifices with a piece of aluminium foil.
- 5) Brush the inside and bottom of the grill with a stiff wire brush and wash down with a mild soap and warm water solution. Rinse thoroughly and let dry.

IMPORTANT: DO NOT line the bottom of the grill housing with aluminium foil, sand, or any other grease absorbent substance. Grease will not be able to drip down into the grease collector and a grease fire could occur. It is that you use Bull Grease Tray Liners (Ref SKU# 24268) for ease clean up and maintenance.

STAINLESS STEEL CLEANING AND MAINTENANCE

Your Grill's outstanding luster and durability is attributed to Stainless Steel construction. Stainless Steel has an outer layer that relies on a proper cleaning and maintenance routine as the best way to prevent corrosion. Please note, Stainless Steel is **not** 'rust proof' contrary to widespread belief. Grills are at higher risk of corrosion by exposure to chemicals, caustics and fertilizers from swimming pools and outdoor landscaping. Locations with climates with greater heat and humidity will intensify this condition. By following a proper cleaning routine, you will add to the years you enjoy your Bull grill.



REQUIRED INSTALLATION, OPERATION AND MAINTENANCE INSTRUCTIONS THAT MUST BE FOLLOWED PER ANSI Z210.58-CSA 1.6-2019 SECTION 4.24.2a FOR ALL OUTDOOR COOKING GAS APPLIANCES.

- I. Installation must conform with local codes or, in the absence of local codes, with either of the following as applicable:
 - a. National Fuel Gas Code, ANSI Z223.1/NFPA 54
 - b. National Gas and Propane Installation Code, CSA B149.1
 - c. Propane Storage and Handling Code. CSA B149.2
 - d. Standard for Recreational Vehicles, ANSI A119.2/NFPA 1192 OR Recreational Vehicle Code, CSA Z240 RV Series
- II. If an electrical source is utilized, the outdoor cooking gas appliance, when installed must be electrically grounded in accordance with local codes, or in the absence of local codes with the refer to National Electrical Code, ANSI/INFPA 70 or Canadian Electrical Code, Part 1, CSA C22 the following as applicable:
- III. This outdoor cooking gas appliance shall be used only outdoors and shall not be used in a building, garage, or any enclosed area.
- IV. This outdoor cooking appliance is not intended to be installed in or on boats.
- V. This outdoor cooking appliance is not intended to be installed in or on recreational vehicles.
- VI. Do not remove any labels, nameplate or data plate that show the manufacturer's, distributor's, jobber or dealer's name, manufacture's address, model name or serial number.
- VII. **YOUR GRILL'S MINIMUM CLEARANCE FROM THE BACK AND SIDE OF ANY COMBUSTIBLE CONSTRUCTION MUST BE AT 21 INCHES MUST NOT BE UNDER OVERHEAD COMBUSTIBLE CONSTRUCTON.**

REFER TO MANUAL PAGES LISTED BELOW FOR GRILL INSPECTION, MAINTENANCE OR SAFETY GUIDELINES:

PAGE 3

- CHECKING AND CLEANING OF BURNER/VENTURI TUBES OF INSECTS AND INSECT NESTS.
- **PAGE 3 OR 13 GAS LEAK TESTING PROCEDURES**
- **PAGE 4** LP HOSE INSPECTION PRIOR TO EACH USE. ENCLOSED GRILLS MUST HAVE ACCESS TO INSPECT THE HOSE AND CONNECTIONS. UPON INSPECTION, A HOSE WITH ANY CUTS, SLITS, TEARING, EXCESSIVE ABRASION OR WEAR. **MUST BE REPLACED, DO NOT USE.** REFER TO PAGES 25, THROUGH 32 TO ORDER REPLACEMENT LP HOSE.

PAGE 13-15

- INSTRUCTIONS AND ILLUSTRATIONS FOR LIGHTING AND GRILL CONTROL OPERATION.
- INSTRUCTIONS AND ILLUSTRATIONS FOR VISUALLY CHECKING THE BURNER AND PILOT FLAME

PAGE 17 AND 32

ROTISSERIE INSTALLATION TO GRILL

PAGE 25-3 INFO AND LOCATIONS FOR ORDERING REPLACEMENT PARTS

A CLOGGED TUBE CAN LEAD TO FIRE BENEATH THE GRILL.

- REQUIRING OUTDOOR GAS APPLIANCE TO BE CLEAR AND FREE OF COMBUSTIBLE MATERIALS, GASOLINE, OR OTHER LIQUIDS EMITTING FLAMMABLE VAPORS.
- DO NOT ALLOW OBSTRUCTION OR RESTRICTION TO THE FLOW OF COMBUSTION AND VENTILATION AIR AROUND GRILL HOUSING.
- KEEPING THE VENTILATION OPENING OF THE CYLINDER ENCLOSURE FREE AND CLEAR FROM DEBRIS.
- KEEPING ELECTRICAL SUPPLY CORD AND FUEL SUPPLY HOSE AWAY FROM ANY HEATED SURFACES.

PAGE 19 BURNER INSPECTION INSTRUCTIONS THAT SHOULD BE DONE MONTHLY.

PAGE 20 THE IMPORTANTANCE OF BURNER ORIFICES BEING PROPERLY INSERTED INTO THE BURNER TUBES.

If the valve orifices do not fit inside the burner tubes, lighting the burners may cause explosion and/or fire.

PAGE 22

- CLEANING THE GRILL, INCLUDING SPECIAL SURFACES AND RECOMMENDED CLEANING AGENTS.



TROUBLESHOOTING



NEVER SMOKE DURING TROUBLESHOOTING



IF GRILL FAILS TO OPERATE PROPERLY

/ Turn off gas at source, turn control knobs to “OFF,” and wait five minutes before trying again.

/ Check gas supply/connections.

Repeat lighting procedure. If Grill still fails to operate properly, **TURN “OFF” GAS AT SOURCE, TURN CONTROL KNOBS TO “OFF,”** wait for grill to cool, and check for the following potential causes below and how to address:

MISALIGNMENT OF BURNER TUBE(S) OVER ORIFICE(S) / CORRECTION:

Reposition burner tube to properly seat over orifice.

OBSTRUCTION IN GAS LINE /CORRECTION:

/ Remove fuel line from grill.

/ Open gas supply for one second to blow any obstruction from fuel line.

/ Close off the gas supply at source and reconnect the fuel line to grill.

PLUGGED BURNER ORIFICE/ CORRECTION:

To access a Burner Orifice:

/ Start by following the instructions on pages 18 to allow Burner removal and inspection.

/ Next, carefully lift each burner up and away from the gas valve orifice. Remove the orifice from each burner up and away from gas valve and gently clear any obstruction with a fine wire. **If an obstruction is in the in-gas valve(s) or gas valve bracket, please contact your gas grill dealer or gas appliance service person for assistance.**

/ Re-install the orifice.

/ Per page 20 reinstall burners over orifices and seat each burner peg. Perform Burner igniter test to confirm it is working.

/ Replace cooking components and grease collectors before attempting to light grill.

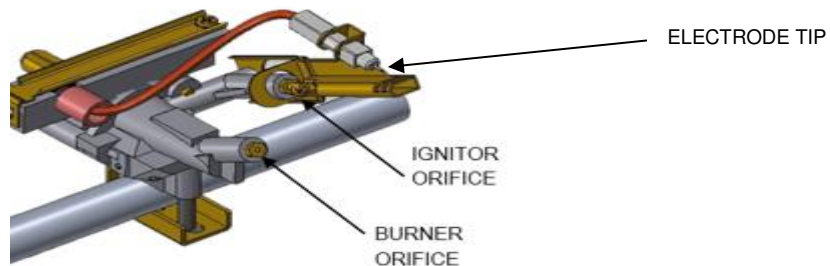

MISALIGNMENT OF IGNITER ON BURNER / CORRECTION

/ Check for proper position of electrode tip. The tip of the electrode should be pointing forward toward the front and free from grease where the spark discharges.

/ The ignition wire should be rigidly connected to the valve ignition and electrode.

/ Replace the ignition wire if the wire is broken or cracked. With gas supply closed and all control knobs set to “OFF,” check each positive igniter individually for presence of spark at electrode. In turn, push each control knob in fully and rotate about 1/4 turn to the left counterclockwise until click is heard; the trigger hitting the strike block should produce a blue spark at the electrode tip. Return control knob to “OFF” before checking the next igniter.

IF RE-IGNITION IS NECESSARY

While the gas grill is still hot, you must wait for a minimum of five minutes before commencing to re-ignite (this allows accumulated gas fumes to clear). If all checks/corrections have been made and the gas grill still fails to operate properly, consult your grill dealer or gas appliance service person.

FLAME COLOR / CORRECTION

/ Once the entire burner is operating, check the flame color to be sure it is mostly blue (some yellow color will be present because of impurities in the fuel).

/ If the flame is golden or yellow in color the reason could be seasoning salts, oil film, or other foreign matter on burner.

/ Remove burners and use compressed air to blow out residue from the interior of burner.

FLASHBACK When fire occurs in and around the burners, immediately turn off gas at its source and turn the control knob(s) to “OFF” Wait until the grill has cooled, then clean the burners and burner ports as described on page 18.



PRODUCT WARRANTY AND REGISTRATION

Thank you for choosing Bull Outdoor Products. To enable our commitment to your satisfaction, you will need to register your purchase for it to be covered under Bull's warranty policy. Please save your purchase receipt as it is required for warranty claims. Additionally, registering your purchase will allow Bull or your Bull Authorized Dealer to utilize the encoded information for the purpose of ordering replacement parts or additional accessories to ensure your purchase remains in optimal working condition. To validate your warranty, we offer two options as shown below:

OPTION 1 / Registering Online

Registration can be completed on the Bull Customer Service Portal, found here <https://api.bullbbq.com/c/>

OPTION 2 / Registering by Mail

Complete the Product Warranty Registration Card that will be in the shipping box (see reference)

Send to: BULL OUTDOOR PRODUCTS, INC.
15 East Ave. Athens, TN 37303
Attn: Warranty Service Center

Warranty Questions call Customer Service at (800) 521-2855

Bull Outdoor Products Warranty Registration Card 

Name _____ Date of Purchase _____

Place of Purchase _____

Email Address _____ Phone _____

Street Address _____ Apt # _____

City _____ State _____ Zip Code _____

How To Register
 On Our Website: <https://api.bullbbq.com/c/>
 Via Mail: Fill out this form and mail it to us!

Model Name: _____

Model Number: _____

Serial Number: _____

Scan This Code With Your Phone: 

UNPACKING THE SHIPPING BOX

Go to <https://bullbbq.com/bull-support-videos/> where we show you how to unbox, install components, and more.

AFTER OPENING THE SHIPPING BOX, inspect THE CONTENTS For any damage and contact our service center or local dealer for replacement of any damaged parts. if damaged do not attempt installation.

ORDERING REPLACEMENT PARTS

Please refer to your owner's manual parts list and illustration to identify what you need.

Below are options for ordering, if you have not yet register your purchase, please register on our website as soon as possible as this information is essential for ordering replacements.

MODEL AND SERIAL NUMBER LOCATION

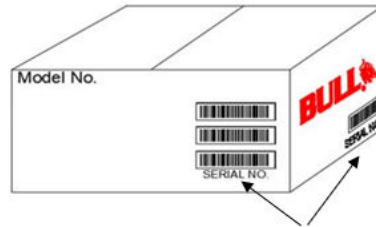

SIDES OF THE SHIPPING BC

To Order Replacement Parts by Phone:

We have two Authorized Parts Distributors ready to assist.

To Order Replacement Parts online

go to: <https://bullbbq.com/buy-parts>

CAUTION:

Concerning the conversion of gas fired products from Liquid Propane to Natural Gas or vice versa. The gas valve is factory pre-set specifically for the type of gas for which the product was designed. A different or specific gas valve must be installed when converting from one gas type to another. Before beginning this process, it is imperative to consult with your gas supplier or your Bull Dealer. Please be advised that conversion kits are exclusively sold to professionals authorized to perform conversion services. Inadequate conversion of the unit may result in severe injury to yourself and/or others, cause irreparable product damage and void the warranty.



Western Region
(800)258-6810

Eastern Region
(800)229-3056

WARNING: Use of any part that is not factory authorized will void your warranty and may be dangerous.



SERIAL NUMBER LOCATIONS ON GRILL

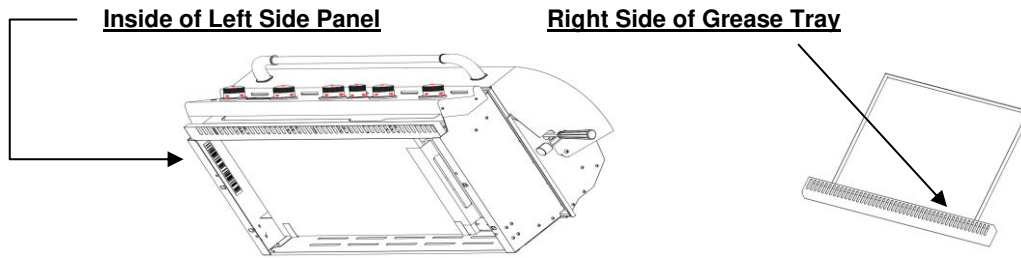

OUTLAW GRILL REPLACEMENT PARTS LIST

SKU# 26038 LP & 26039 NG (Any item with a * next to it requires a serial number)

# NO. USED IN PARTS LIST ILLUSTRATION (NEXT PAGE)	BULL SKU NO.	PART DESCRIPTION * INDICATES GRILL SERIAL NUMBER REQUIRED	QTY	WARRANTY PERIOD (YEARS)
1	47003	INSERT ASSEMBLY (2016 & OLDER MODELS)	1	Lifetime
2	47023	INSERT ASSEMBLY (2017 & NEWER MODELS)	1	Lifetime
3	16517	COOKING GRATE	4	Lifetime
4	44305	WELDED STAINLESS STEEL BURNER	4	5
5	47004	WARMING RACK	1	3
6	26103	MANIFOLD	1	3
7	16631	VENTED FLAME TAMER	4	3
8	16670	HEAT SHIELD	3	3
9	16522	LID HANDLE END CAP	2	3
10	16523	LID HANDLE CENTER BAR	1	3
11	47019	LID - FRONT	1	↑ 1 YEAR ↓
12	16635	RUBBER BUMPER FOR LID	2	
13	16690	LARGE TEMPERATURE GAUGE	1	
14	16692	LARGE TEMPERATURE GAUGE BEZEL	1	
15	47031	LID - REAR (2016 & OLDER MODELS)	1	
16	47032	LID - REAR (2017 & NEWER MODELS)	1	
17	47012	COVER - REAR LID	1	
18	47022	COVER - REAR LID (2017 & NEWER MODELS)	1	
19	47008	BACK PANEL (2016 & OLDER MODELS)	1	
20	47024	BACK PANEL (2017 & NEWER MODELS)	1	
21	47011	GREASE TRAY	1	
22	97022	LIGHTING ROD WITH CHAIN	1	
23	26101	CONTROL PANEL	1	
24	16571	LOGO PLATE FOR CONTROL PANEL	1	
25	16629	BEZEL - MAIN BURNER	4	
26	16613	KNOB - MAIN BURNER	4	
27	16525	GAS VALVE - MAIN BURNER (LIQUID PROPANE MODEL ONLY)	4	
28	16589	LP HOSE AND REGULATOR (LIQUID PROPANE MODEL ONLY)	1	
29	16598	FLARE TO FLARE UNION (LIQUID PROPANE MODEL ONLY)	1	
30	16524	GAS VALVE-MAIN BURNER (NATURAL GAS MODEL ONLY)	4	
31	16507	REGULATOR (NATURAL GAS MODEL ONLY)	1	
32	16599	REGULATOR ADAPTER (NATURAL GAS MODEL ONLY)	2	
33	47006	STAINLESS FLEX TUBE	1	

WARNING: Use of any part that is not factory authorized will void your warranty and may be dangerous



OUTLAW GRILL REPLACEMENT PARTS ILLUSTRATION

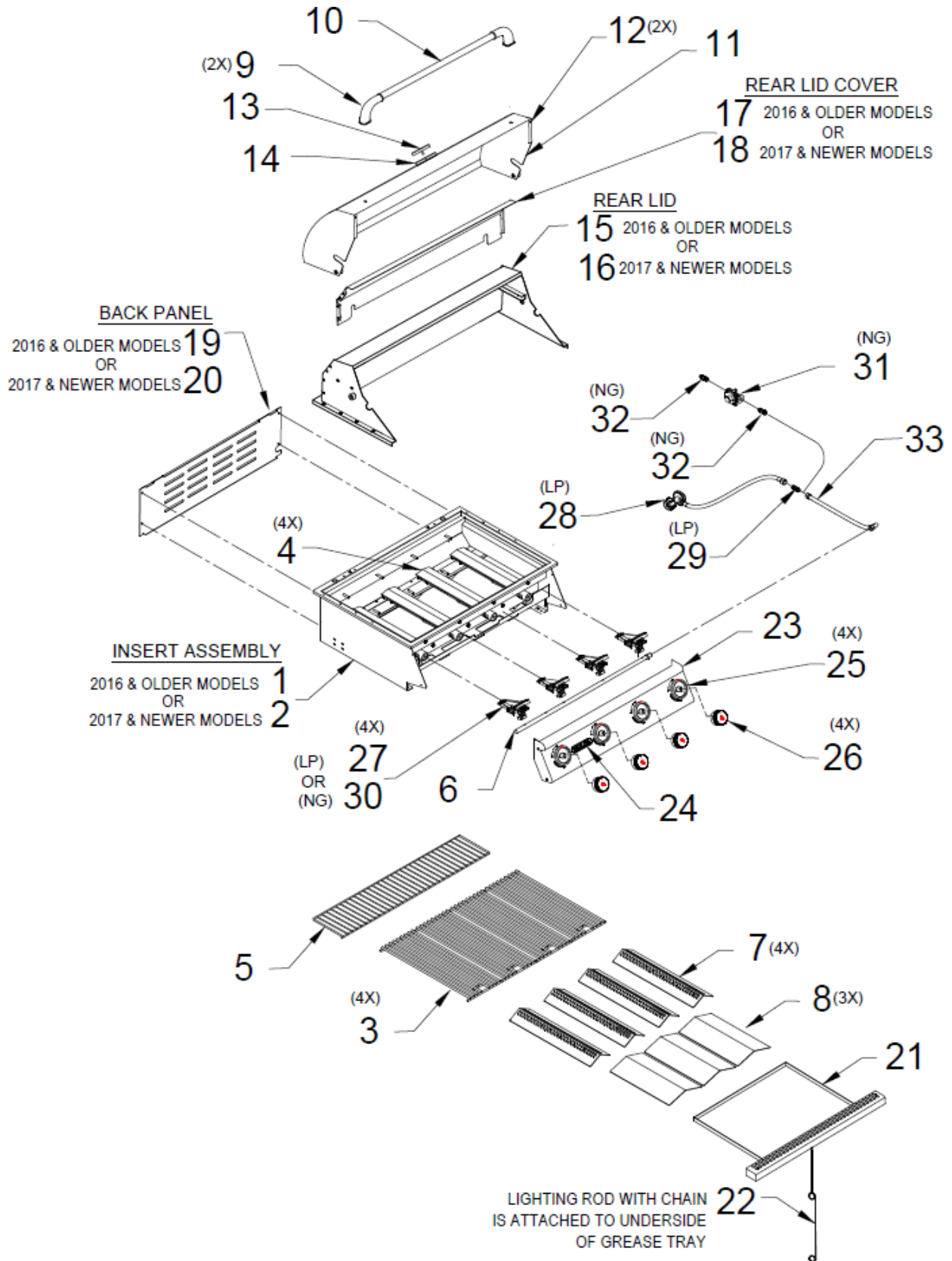



WARNING: Use of any part that is not factory authorized will void your warranty and may be dangerous



LONESTAR SELECT GRILL REPLACEMENT PARTS LIST

SKU# 87048 LP & 87049 NG (Any item with an * next to it requires a serial number)

NUMBER USED ON ILLUSTRATION, PG 33	BULL SKU NO.	DESCRIPTION * SERIAL NUMBER REQUIRED	QTY	WARRANTY PERIOD (YEARS)
1	47003	INSERT ASSEMBLY (2016 & OLDER MODELS)	1	Lifetime
2	47023	INSERT ASSEMBLY (2017 & NEWER MODELS)	1	Lifetime
3	16517	COOKING GRATE	4	Lifetime
4	44305	WELDED STAINLESS STEEL BURNER	4	5
5	47004	WARMING RACK	1	3
6	26103	*MANIFOLD	1	3
7	16631	VENTED FLAME TAMER	4	3
8	16670	HEAT SHIELD	3	3
9	16522	LID HANDLE END CAP	2	3
10	16523	LID HANDLE CENTER BAR	1	3
11	47019	LID - FRONT	1	 1 YEAR 
12	16635	RUBBER BUMPERS FOR LID	2	
13	16690	LARGE TEMPERATURE GAUGE	1	
14	16692	LARGE TEMPERATURE GAUGE BEZEL	1	
15	87101	LID - REAR (2016 & OLDER MODELS)	1	
16	87103	LID - REAR (2017 & OLDER MODELS)	1	
17	47012	COVER - REAR LID (2016 & OLDER MODELS)	1	
18	47022	COVER - REAR LID (2017 & NEWER MODELS)	1	
19	47008	BACK PANEL (2016 & OLDER MODELS)	1	
20	47024	BACK PANEL (2017 & NEWER MODELS)	1	
21	47011	GREASE TRAY	1	
22	97022	LIGHTING ROD WITH CHAIN	1	
23	47006	*STAINLESS FLEX TUBE	1	
24	87102	CONTROL PANEL	1	
25	16571	LOGO PLATE FOR CONTROL PANEL	1	
26	16629	BEZEL - MAIN BURNER	4	
27	16613	KNOB - MAIN BURNER	4	
28	16525	GAS VALVE - MAIN BURNER (LIQUID PROPANE MODEL ONLY)	4	
29	16524	GAS VALVE-MAIN BURNER (NATURAL GAS MODEL ONLY)	4	
30	16507	REGULATOR (NATURAL GAS MODEL ONLY)	1	
31	16599	REGULATOR ADAPTER (NATURAL GAS MODEL ONLY)	2	
32	16598	FLARE TO FLARE UNION (LIQUID PROPANE MODEL ONLY)	2	
33	16589	LP HOSE AND REGULATOR (LIQUID PROPANE MODEL ONLY)	2	
34	16612	*PUSH BUTTON LIGHT SWITCH	1	
35	16638	*QUICK-DISCONNECT LIGHT WIRE HARNESS	1	
36	16634	QUICK DISCONNECT TRANSFORMER PIGTAIL	2	
37	16534	*TRANSFORMER	1	
38	16627	*LIGHT HOUSING	2	
39	16530	*LIGHT LENS	2	
40	16529	*LIGHT LENS CLIP	2	
41	16532	LIGHT BULB	2	N/A

WARNING: Use of any part that is not factory authorized will void your warranty and may be dangerous



LONESTAR SELECT GRILL REPLACEMENT PARTS ILLUSTRATION

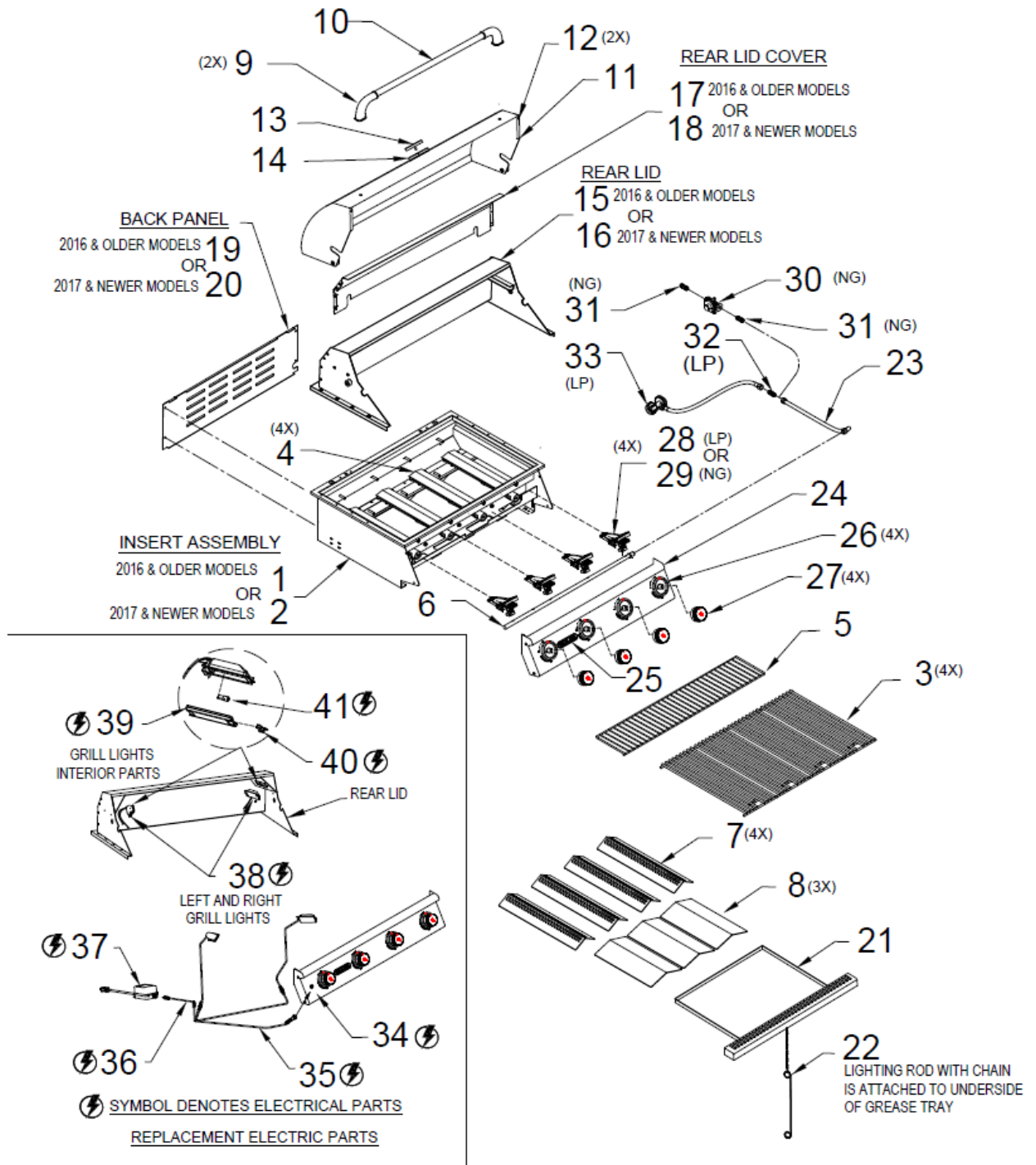

WARNING: Use of any part that is not factory authorized will void your warranty and may be dangerous.



ANGUS GRILL REPLACEMENT PARTS LIST

SKU# 47628 LP & 47629 NG (Any item with an * next to it requires a serial number)

NUMBER USED ON ILLUSTRATION, NEXT PAGE	BULL SKU NO.	DESCRIPTION * SERIAL NUMBER REQUIRED	QTY	WARRANTY PERIOD (YEARS)
1	47003	INSERT ASSEMBLY (2016 & OLDER MODELS)	1	Lifetime
2	47023	INSERT ASSEMBLY (2017 & NEWER MODELS)	1	Lifetime
3	35717	CAST STAINLESS STEEL BURNER	4	Lifetime
4	16517	COOKING GRATE	4	Lifetime
5	47004	WARMING RACK	1	3
6	16631	VENTED FLAME TAMER	4	3
7	16670	HEAT SHIELD	3	3
8	47005	*MANIFOLD	1	3
9	16522	LID HANDLE END CAP	2	3
10	16523	LID HANDLE CENTER BAR	1	3
11	47019	LID - FRONT	1	↑ 1 YEAR ↓
12	16635	RUBBER BUMPER FOR LID	2	
13	16692	LARGE TEMPERATURE GAUGE BEZEL	1	
14	16690	LARGE TEMPERATURE GAUGE	1	
15	47002	LID - REAR (2016 & OLDER MODELS)	1	
16	47021	LID - REAR (2017 & NEWER MODELS)	1	
17	47012	COVER - REAR LID (2016 & OLDER MODELS)	1	
18	47022	COVER - REAR LID (2017 & NEWER MODELS)	1	
19	47008	BACK PANEL (2016 & OLDER MODELS)	1	
20	47024	BACK PANEL (2017 & NEWER MODELS)	1	
21	47010	CONTROL PANEL	1	
22	16571	LOGO PLATE FOR CONTROL PANEL	1	
23	47011	GREASE TRAY	1	
24	97022	LIGHTING ROD WITH CHAIN	1	
25	16629	BEZEL - MAIN BURNER	4	
26	16613	KNOB - BACK BURNER	4	
27	16617	KNOB - MAIN BURNER	1	
28	16630	BEZEL - BACK BURNER	1	
29	16525	GAS VALVE - MAIN BURNER (LIQUID PROPANE MODEL ONLY)	4	
30	16524	GAS VALVE-MAIN BURNER (NATURAL GAS MODEL ONLY)	4	
31	16526	GAS VALVE - BACK BURNER (LIQUID PROPANE OR NATURAL GAS MODEL)	1	
32	16598	FLARE TO FLARE UNION (LIQUID PROPANE MODEL ONLY)	1	
33	16589	LP HOSE AND REGULATOR (LIQUID PROPANE MODEL ONLY)	1	
34	16507	REGULATOR (NATURAL GAS MODEL ONLY)	1	
35	16599	REGULATOR ADAPTER (NATURAL GAS MODEL ONLY)	2	
36	47006	*STAINLESS FLEX TUBE	1	
37	47007	*INFRARED ROTISSERIE BACK BURNER	1	
38	47009	*BACK BURNER STAINLESS FLEX TUBE	1	
39	16527	*BACK BURNER ORIFICE (LIQUID PROPANE MODEL ONLY)	1	
40	16528	*BACK BURNER ORIFICE (NATURAL GAS MODEL ONLY)	1	
41	16512	BACK BURNER IGNITION WIRE	1	
42	16511	BACK BURNER ELECTRODE	1	
43	16671	BACK BURNER ORIFICE AIR INLET GUARD	1	
44	16672	BACK BURNER ELECTRODE GUARD	1	
45	16612	*PUSH BUTTON LIGHT SWITCH	1	
46	16634	QUICK DISCONNECT TRANSFORMER PIGTAIL	1	
47	16638	*QUICK-DISCONNECT LIGHT WIRE HARNESS	1	
48	16534	*TRANSFORMER	1	
49	16627	*LIGHT HOUSING	2	
50	16530	*LIGHT LENS	2	
51	16529	*LIGHT LENS CLIP	2	
52	16532	LIGHT BULB	2	N/A

WARNING: Use of any part that is not factory authorized will void your warranty and may be dangerous



ANGUS GRILL REPLACEMENT PARTS LIST ILLUSTRATION

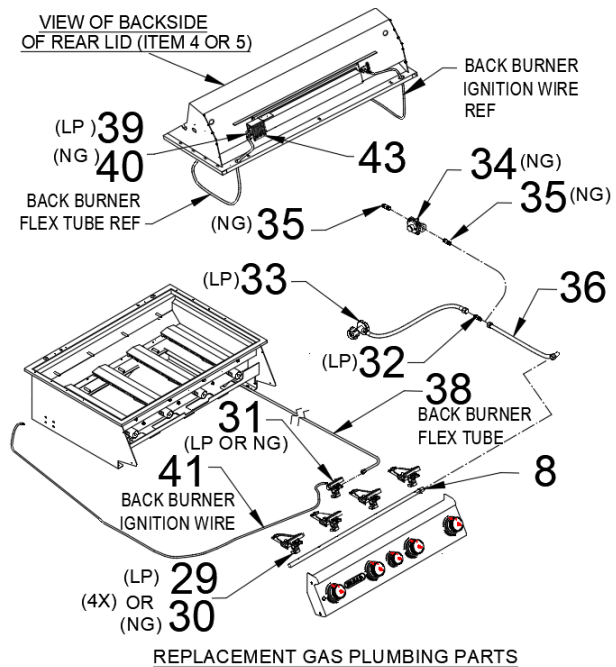
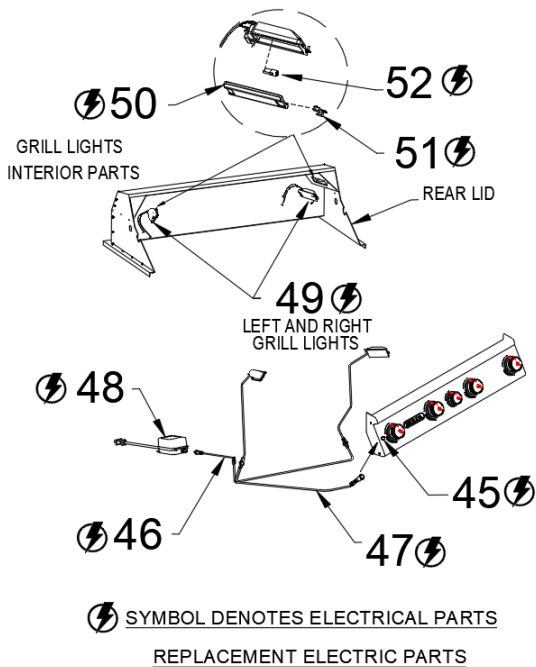
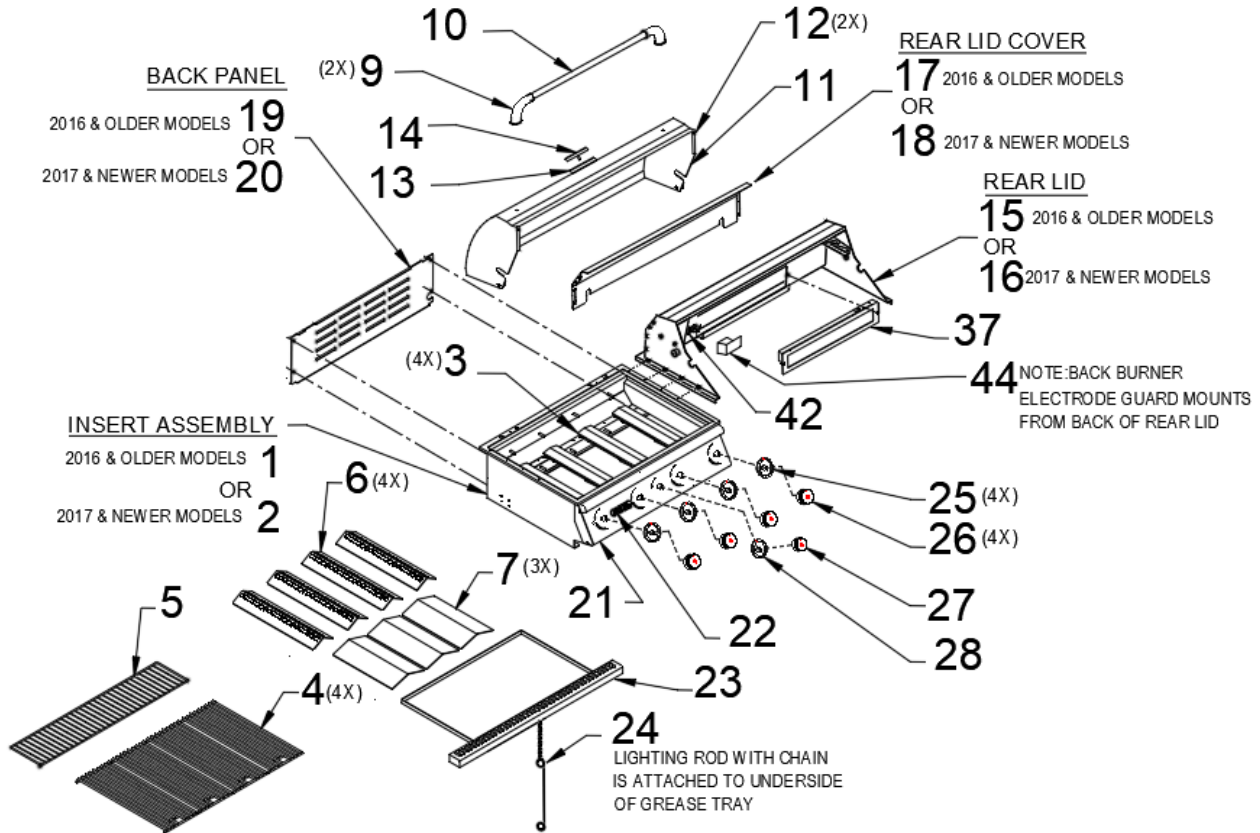

WARNING: Use of any part that is not factory authorized will void your warranty and may be dangerous



**ROTISSERIE SYSTEM PARTS LIST WITH EXPLODED ILLUSTRATION
AND INSTALL INSTRUCTIONS**

REF #	SKU #	DESCRIPTION	QTY
1	16552	110 VAC MOTOR W/SWITCH	1
2	16554	MOTOR MOUNT BRACKET	1
3	16551	30" GRILL SPIT ROD	1
4	16553	LARGE 4-PRONG SPIT FORK	2
5	16591	SHAFT COLLAR	1
6	16587	1/4-20 X 1/2 THUMBSCREW	3
7	16675	KEY WASHER	1
8	16586	COUNTER-BALANCE	1
9	16585	BLACK PHENOLIC HANDLE	1

WARRANTY IS 1 YEAR FOR ALL PARTS

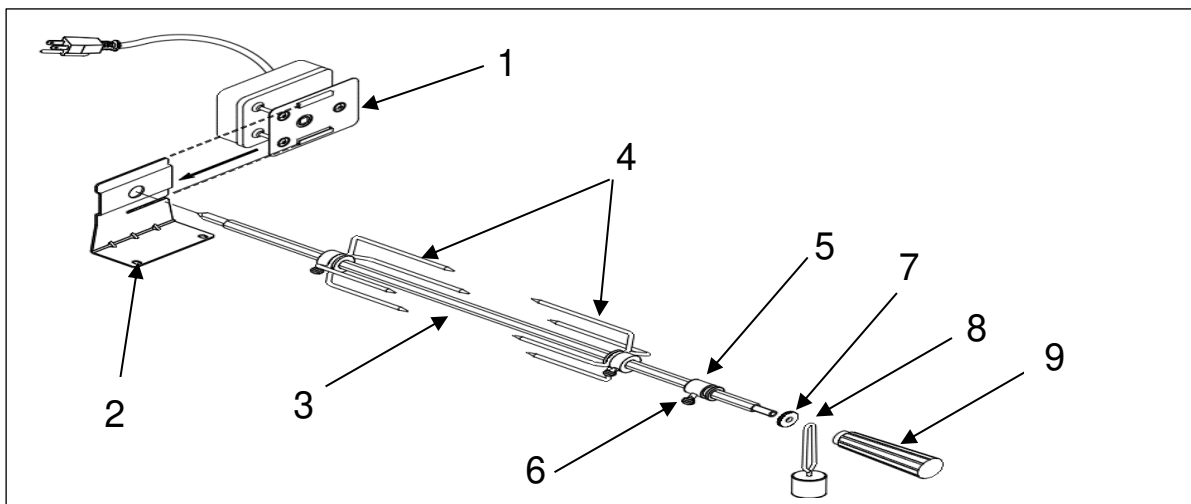

WARNING: Use of any part that is not factory authorized will void your warranty and may be dangerous.

ROTISSERIE MOTOR MOUNTING BRACKET INSTALLATION

The Rotisserie Motor slides on to the bracket and is bolted to the flange on the outside of the grill. Use the first 2 mounting holes.

as shown to align the motor with slot on the grill lid that the spit goes through. The bracket can be installed on either side of the unit.

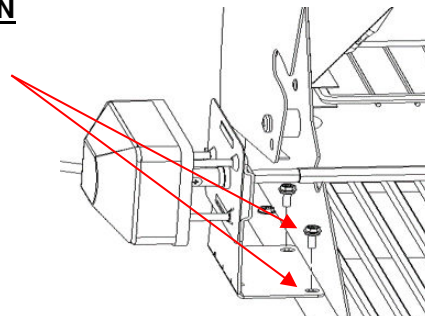

**REFER TO
PAGE 17 FOR
OPERATING
INSTRUCTIONS**



Warranty Policy

LIMITED WARRANTY ON BULL OUTDOOR PRODUCTS, INC., PRODUCTS

THIS LIMITED WARRANTY GIVES YOU SPECIFIC LEGAL RIGHTS. YOU MAY ALSO HAVE OTHER RIGHTS, WHICH VARY FROM STATE TO STATE.

THIS LIMITED WARRANTY CAN ALSO BE FOUND ON OUR WEBSITE AT:

<https://www.bullbbq.com/support-warranty> (United States Customers)

<https://www.bullbbq.eu/customer-care/#warranty-registration-form> (International Customers)

AND IN THE OWNER'S/INSTALLATION MANUALS THAT WE PROVIDE WITH OUR PRODUCT

THIS LIMITED WARRANTY IS SUBJECT TO THE EXCLUSIONS, CONDITIONS AND LIMITATIONS SET FORTH BELOW.

ANY IMPLIED WARRANTIES IMPOSED BY LAW, INCLUDING WITHOUT LIMITATION TO THE IMPLIED WARRANTIES OF MERCHANTABILITY AND FITNESS FOR A PARTICULAR PURPOSE, ARE LIMITED IN DURATION TO THE DURATION OF THIS EXPRESSED LIMITED WARRANTY. SOME STATES DO NOT ALLOW LIMITATIONS ON HOW LONG AN IMPLIED WARRANTY LASTS, SO THE ABOVE LIMITATION MAY NOT APPLY TO YOU.

WHO MAY USE THIS WARRANTY?

BULL OUTDOOR PRODUCTS, INC. located at address 1101 East Pine St. Lodi, CA. 95240 (“we”) extend this limited warranty only to the consumer who originally purchased the product (“you”) at the original site of delivery or installation. It does not extend to any subsequent owner or other transferee of the product. It does not extend to any rental, commercial, or non- residential application. Examples of excluded applications include, but are not limited to day care centers, schools, bed and breakfast centers, churches, private clubs, fire stations, club houses, Common areas in multi-family dwellings, restaurants, hotels, nursing homes, food service locations, and institutional food service locations.

WHAT DOES THIS WARRANTY COVER?

This limited warranty covers defects in materials and workmanship of the product and product components identified below for the Warranty Periods defined below.

WHAT IS THE PERIOD OF COVERAGE?

This limited warranty starts on the date of your purchase and lasts for the time periods specified on the next page. The Warranty Period is not extended if we replace the product. We may change the availability of this warranty at our discretion, but any changes will not be retroactive.



Warranty Policy (Continued)

Grilling/Pizza Accessories and Grill Covers DO NOT include a warranty period

Grill Warranty Periods

The following parts are covered for **1 year** on all our current gas grill models:

- The lid, control panel, grease tray, bezels, knobs, temperature gauge, valves, regulator, flex tubes, rotisserie burner, transformer, and all components of the lighting system.

The following parts are covered for **3 years** on all our current gas grill models:

- The manifold, handle end caps, flame tamers, heat shields, and warming rack.

The following parts are covered for the **Lifetime** on all our current gas grill models:

- Insert assembly and the grates.

The warranty period for the grill burners varies by type:

- Cast stainless steel burners - **Lifetime**
- Welded stainless steel burners - **5 years**
- Porcelain coated burners - **3 years**

The warranty period for the charcoal grill is **1 year** on all parts, except for the insert assembly, which is covered for **5 years**.

Component Warranty Periods

All the parts for our components /grill carts/refrigerators/kegerators/drawers/doors/refrigerator frames/grill

jackets/finishing frames/ice chest/sinks/bar center are covered for **1 year** with these exceptions:

- **Power Burner**
 - The insert/grates are **lifetime** covered parts.
 - The manifold/burner are covered for **3 years**.
- **Searing Station/Slide in Double Sideburner**
 - The grates are covered for **lifetime**.
 - The insert for **5 years**, and
 - The manifold for **3 years**.
- **Single Sideburner**
 - The grates are covered for **5 years** and
 - The burner for **3 years**.
- **Sidekick**
 - The burner is covered for **3 years**.

Pizza Ovens/Islands/Fire Features Warranty Periods

- All of the parts and construction materials are covered for **1 year**.



Warranty Policy (Continued)

WHAT DOES THIS WARRANTY NOT COVER?

This limited warranty does not cover any damage due to:

- Transportation.
- Storage
- Improper installation or use.
- Use on improper fuel/gas supply.
- Failure to follow the product instructions or to perform any preventive maintenance.
- Modifications.
- Normal wear and tear, rust, corrosion, oxidation, or discoloration.
- External causes such as accidents, abuse, or other actions or events beyond our reasonable control.

WHAT OPTIONS ARE OFFERED BY BULL OUTDOOR PRODUCTS UNDER THIS WARRANTY?

With respect to any defective product claim made during the Warranty Period, we will, in our sole discretion:

- Replace such product (or the defective part) free of charge.

WHAT IS EXCLUDED BY BULL OUTDOOR PRODUCTS UNDER THIS WARRANTY?

- We will not pay for shipping charges for replacement parts, or for any labor or labor related charges.
- We will not pay for any accessory products or ancillary products purchased by you for use in connection with the product.

HOW DO YOU NOTIFY BULL CUSTOMER SERVICE OF A POTENTIAL WARRANTY ISSUE?

Our Customer Service is ready to help. Here's how to reach us:



By Phone (800) 521-2855 Monday through Friday from 8:00 a.m. to 5:00 p.m. (EDT)



To submit a warranty, claim on-line or message go to <https://www.bullbbq.com/support-warranty.com>

LIMITATION OF LIABILITY

THE REMEDIES DESCRIBED ABOVE ARE YOUR SOLE AND EXCLUSIVE REMEDIES AND OUR ENTIRE LIABILITY FOR ANY BREACH OF THIS LIMITED WARRANTY. OUR LIABILITY SHALL UNDER NO CIRCUMSTANCES EXCEED THE ACTUAL AMOUNT PAID BY YOU FOR THE DEFECTIVE PRODUCT, NOR SHALL WE UNDER ANY CIRCUMSTANCES BE LIABLE FOR ANY CONSEQUENTIAL, INCIDENTAL, SPECIAL OR PUNITIVE DAMAGES OR LOSSES, WHETHER DIRECT OR INDIRECT.

SOME STATES DO NOT ALLOW THE EXCLUSION OR LIMITATION OF INCIDENTAL OR CONSEQUENTIAL DAMAGES, SO THE ABOVE LIMITATION OR EXCLUSION MAY NOT APPLY TO YOU.

v2024.05.09