



ASSEMBLY & OPERATING INSTRUCTIONS
MODEL #88787 BISON PREMIUM CHARCOAL GRILL



USA Edition 



TABLE OF CONTENTS

PAGE # 1

REGISTERING YOUR GRILL	2
SAFETY INSTRUCTIONS	3
INSTALLATION INSTRUCTIONS	
SPECIFICATIONS FOR BARBECUE STRUCTURE.....	4
OVERHEAD VENTILATION	5
OPERATING INSTRUCTIONS	
EXCLUSIVE FEATURES.....	6
AFTER USE SAFETY.....	7
CLEANING & MAINTENANCE	
CLEANING THE GRILL.....	8
CLEANING THE COOKING GRATES	
REPLACEMENT PARTS ORDERING INSTRUCTIONS.....	8
REPLACEMENT PARTS LIST & EXPLODED ILLUSTRATION.....	9
LIMITED WARRANTY.....	10-12

REGISTERING YOUR GRILL

To validate your Bull Limited Warranty, you must submit the completed the Warranty Registration Card within 90 days from the date of purchase. Registration can be completed on-line at

https://bullbbq.ladesk.com/submit_ticket

or by sending the completed Warranty Registration Card and copy of your Purchase Receipt or Invoice as proof of purchase to:

BULL OUTDOOR PRODUCTS, INC.
 1011 East Pine St.
 Lodi, CA 95240
 Attn: Warranty Service Center

For Warranty Claims or Replacement Parts ordering, please fill out the area provided below:

PRODUCT INFORMATION REFERENCE CARD

• Model Number _____

• Serial Number _____

(The Serial Number is encoded with essential information for ordering replacement parts or submitting Warranty claims. Location of Serial Numbers is shown below)

• Date of Purchase _____

• Copy of your Purchase Receipt or Invoice.

For Warranty Questions call Customer Service at (800) 521-2855

LOCATION OF SERIAL NUMBERS

Essential information about your product is encoded in the serial number of your grill or cart. This information will be required for all warranty claims, ordering replacement parts and will identify any variations of your unit. It is extremely important that you record your serial number and register your grill from the Proof of Purchase. The grill serial number locations are shown below.

ON THE RIGHT SIDE OF YOUR BISON GRILL

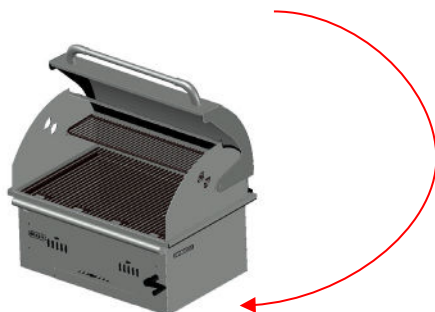

END OF SHIPPING BOX OR INSIDE OF BOX FLAP

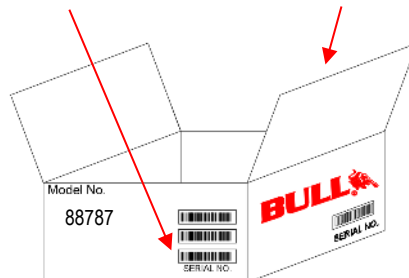



SAFETY INSTRUCTIONS

READ CAREFULLY BEFORE ASSEMBLY AND OPERATION OF YOUR GRILL

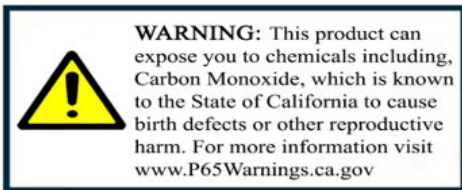

PROTECT CHILDREN:

- Do not allow children to operate the grill.
- Keep children away from the grill during use and until the grill has cooled after you are finished.

NEVER SMOKE DURING USE

SAFETY:

- 1) When using charcoal briquettes or wood chunks, form a pyramid and douse with lighter fluid. Wait until fluid has soaked in before lighting.
- 2) Cap lighter fluid immediately and place at a safe distance from grill.
- 3) **Never** add lighter fluid to coals that are already hot or warm.
- 4) **Never** use gasoline, kerosene or other highly volatile fluids as a starter. They can explode.
- 5) As an alternative to lighter fluid, use an electric, solid or metal chimney or other starter specifically made for lighting charcoal briquettes or wood chunks.
- 6) Unplug and remove a hot starter with caution and be careful where you place it. Always make sure the starter is completely cool before storing.
- 7) **Never** use an electric starter in the rain and/or when standing on wet ground.
- 8) When using instant light briquettes, do not use lighter fluid, electric, solid or metal chimney-style starters. Do not add more instant light briquettes once the fire has been lit. Add only regular charcoal briquettes if more are needed.
- 9) Once the grill is lit, do not touch briquettes or wood chunks to see if they are hot. Keep grill uncovered until ready to cook.
- 10) Keep vents open while cooking. Charcoal briquettes and wood chunks need oxygen to burn.
- 11) Allow coals to burn out completely and let ashes cool at least 48 hours before disposing.
- 12) Dispose of cold ashes by wrapping them in heavy-duty aluminum foil and placing them in a non-combustible container. Be sure no other combustible materials are nearby.
- 13) If you must dispose of ashes before completely cool, place them in heavy-duty foil and soak with water completely before disposing in non-combustible container.

WARNING:

- 14) This grill is designed for outdoor use only. If used indoors, toxic fumes will accumulate and cause serious bodily injury or death.
- 15) **Do not** leave infants, children or pets unattended near a hot grill.
- 16) **Do not** use grill near any combustible materials and/or chemicals. Combustible materials include, but are not limited to, wood or treated wood decks, patios or porches.
- 17) Keep the grill in a level position at all times.
- 18) Always put charcoal on top of the charcoal grate and not directly into the bottom of the bowl.
- 19) Never touch the cooking or charcoal grate or the grill to see if they are hot.
- 20) Use barbecue mitts or hot pads to protect hands while cooking or adjusting the vents.
- 21) Use proper barbecuing tools with long, heat-resistant handles. Lining the bowl with aluminum foil will obstruct the air flow. Instead, use a drip pan to catch drippings from meat when cooking by the indirect method.



INSTALLATION INSTRUCTIONS

PLEASE READ THESE INSTRUCTIONS BEFORE INSTALLING YOUR CHARCOAL GRILL

Your charcoal grill comes to you fully assembled. These instructions and illustration will provide you with the measurements necessary for you or your builder to construct a masonry structure to house your outdoor charcoal grill.

NOTES TO INSTALLER:

- 1) Do not discard these instructions. Leave these instructions with the consumer for future reference.
- 2) Grill is to be used **OUTDOORS ONLY**,
- 3) The grill **must** be installed in accordance with all local building codes.

GRILL INSTALLATION GUIDELINES:

- 1) Do not use any combustible materials for this construction. Your charcoal grill **MUST** be installed in a cabinet constructed using only **non-combustible** materials.
- 2) We do not endorse the use of combustible materials for the floor of the kitchen.
- 3) The minimum horizontal clearance to adjacent combustible surface from side and back of the grill must be **21 inches**.
- 4) Provide 6 inches of clearance behind grill to allow front portion of hood to open and for ventilation purposes.
- 5) **DO NOT** obstruct the removable 15 1/2" x 14" x 2 1/2" ash collection box that must not be obstructed by cabinet construction.

See drawing below for installation dimensions for installing the Grill in an outdoor kitchen.

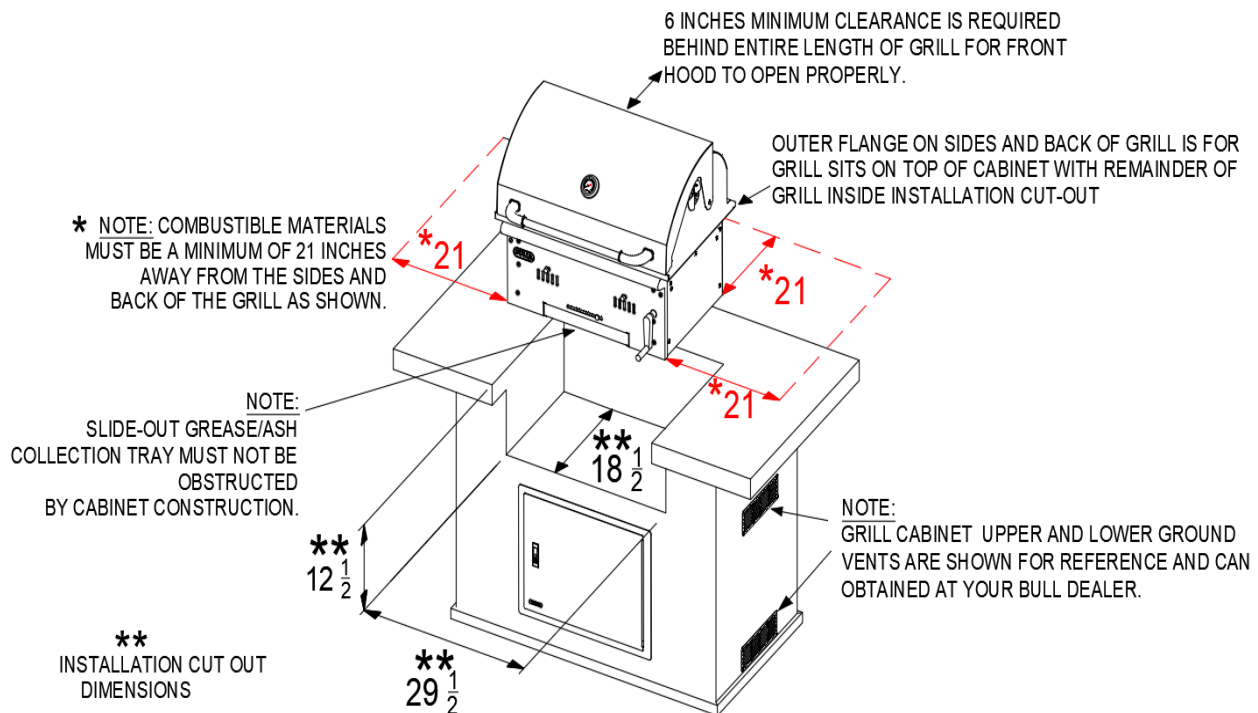

See next page for overhead ventilation.



GRILL OVERHEAD VENTILATION

⚠ IMPORTANT!

DO NOT USE OR INSTALL YOUR GRILL IN THE FOLLOWING LOCATIONS:

- INDOORS
- ENCLOSED AREAS
- BREEZEWAYS
- SCREENED-IN PATIOS
- INSIDE A BUILDING

IF THE GRILL LOCATION HAS OVERHEAD CONSTRUCTION PRESENT YOU **MUST** FOLLOW THESE INSTRUCTIONS:

- 1) DO NOT INSTALL GRILL UNDER A COMBUSTIBLE COVER.
- 2) OVERHEAD CONSTRUCTION ABOVE COOKING SURFACES **MUST** BE NON-COMBUSTIBLE AND **MUST** BE BUILT NO LESS THAN 60 INCHES ABOVE THE COOKING SURFACES UNLESS OTHERWISE STATED BY LOCAL BUILDING AND FIRE CODE REQUIREMENTS.
- 3) A VENTILATION HOOD **MUST** BE INSTALLED ABOVE THE COOKING SURFACE WITH A 30 INCHES MINIMUM CLEARANCE BETWEEN VENTILATION HOOD AND COOKING SURFACE
- 4) VENTILATION HOOD **MUST** BE LARGER THEN THE COOKING SURFACE WITH A MINIMUM OF 3 INCHES OF OVERLAP ON EACH SIDE OF COOKING SURFACE
- 5) VENTILATION HOOD **MUST** BE RATED WITH A MINIMUM OF 1200 CFM (CUBIC FEET PER MINUTE) FOR PROPER APPLICATION.

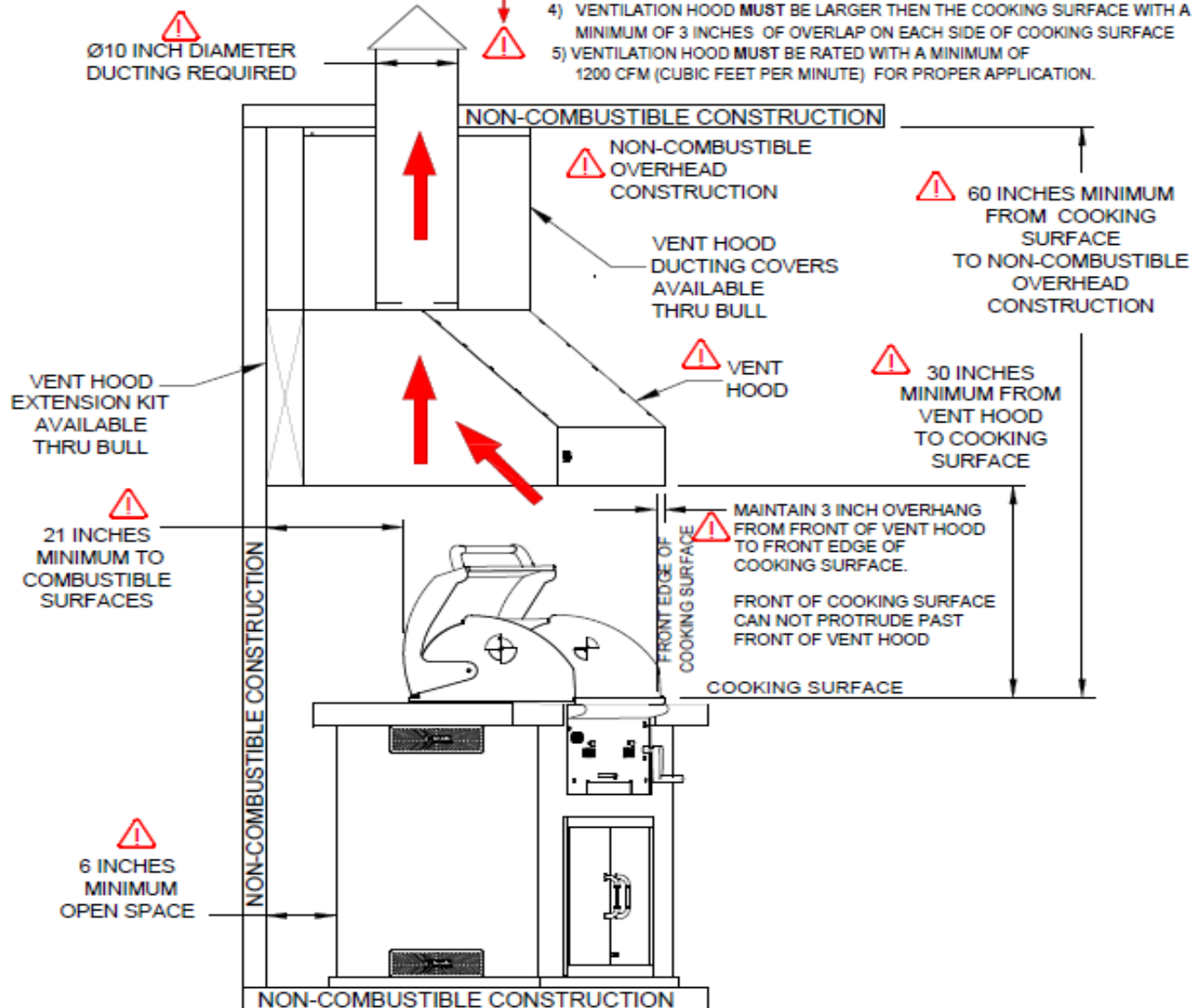



OPERATING INSTRUCTIONS

NOTE:

- 1) Place the grill outdoors on a hard, level, non-combustible surface away from roof overhang or any combustible material.
- 2) **Never** use on wood or other surfaces that could burn.
- 3) Place the grill away from open windows or doors to prevent smoke from entering your house.
- 4) Place the grill in an outdoor area that is protected from the wind.

CAUTION: DO NOT LEAVE GRILL UNATTENDED WHILE IN USE.

EXCLUSIVE FEATURES

- Air vent butterfly dampers at both sides of the lid control rate of burn for your choice of high intensity heat, slow roasting or smoking (see illustrations below).

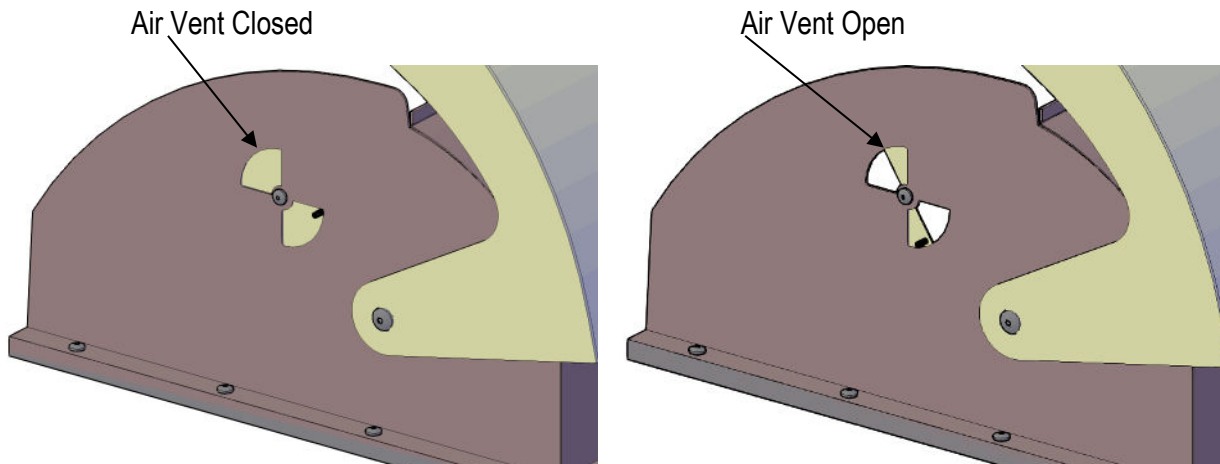

Grill door with air shutter can control the airflow (see illustrations below).

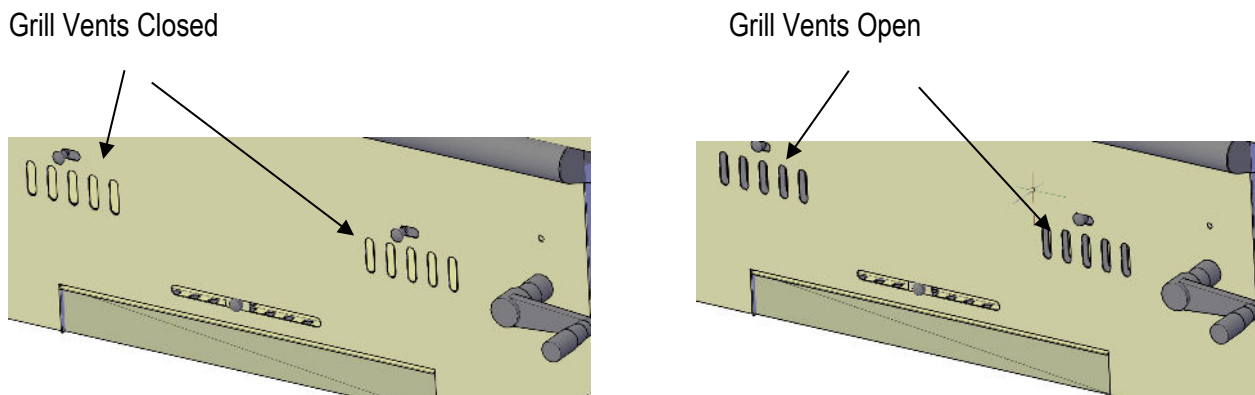



OPERATING INSTRUCTIONS (CONT.)

- Remove Cooking grill to access Charcoal holding trays to load Charcoal Briquets.

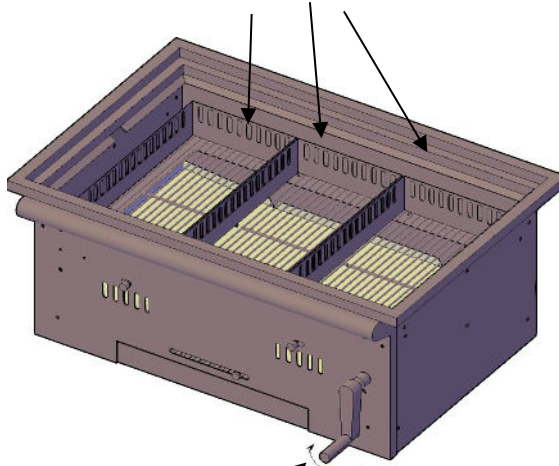

- Rotate the height adjustment knob to adjust the charcoal bed for multi-level heat control

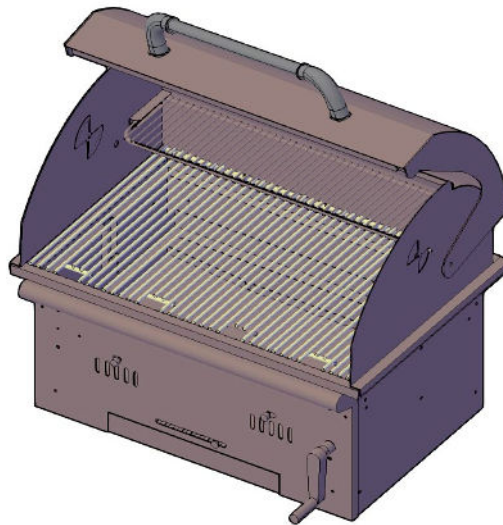

- Qty. 4 Cooking Grates

AFTER USE SAFETY:

- 1) Always allow grill and all components to cool completely before handling.
- 2) Never leave coals and ashes in grill unattended. Make sure coals and ashes are completely extinguished before removing.
- 3) Before grill can be left unattended, remaining coals and ashes must be removed from grill. Place remaining coals and ashes in a non-combustible metal container and completely saturate with water. Allow coals and water to remain in metal container 24 hours prior to disposing.
- 4) Extinguished coals and ashes should be placed a safe distance from all structures and combustible materials.
- 5) With a garden hose, completely wet surface beneath and around the grill to extinguish any ashes, coals or embers which may have fallen during the cookout or cleaning process.
- 6) Cover and store grill in a protected area away from children and pets.



CLEANING & MAINTENANCE

CLEANING THE GRILL

4 easy steps to help you clean your grill:

- Make sure the grill is cool and coals are totally extinguished.
- Remove the cooking and charcoal grates.
- Remove ashes.
- Wash your grill in a mild soap and warm water solution. You can also use a washcloth or a vegetable brush to clean your grill and wipe down.

CLEANING THE COOKING GRATES

Before first use and periodically it is suggested that you wash the cooking grates in a mild soap and warm water solution. You can also use a washcloth or a vegetable brush to clean your cooking grates.

HOW TO ORDER REPLACEMENT PARTS

This is where your Product Information Reference Card will come in handy for supplying necessary info needed by your Bull Authorized Dealer to assure you get the correct part(s) for your Grill or additional accessories to keep your Grill in top working condition. If you don't have the card, you can still get the model number and serial number on the inside of the left side panel. That information is required for parts orders.

Please refer to your owner's manual parts list and illustration to identify what you need.

To Order Replacement Parts on-line go to: <https://www.bullbbq.com/buy-parts>

Ordering Parts by phone:

Bull is ready to help with two regional suppliers
open 8:00 am to 5:00 pm Monday through Friday.

For the Western Region, call (800) 258-6810

For the Eastern Region, call (800) 229-3056

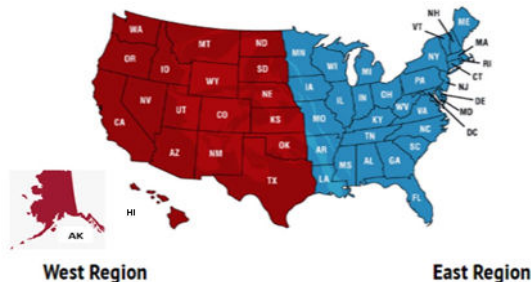

INSPECT FOR ANY DAMAGE AND CONTACT OUR SERVICE CENTER OR LOCAL DEALER FOR REPLACEMENT OF ANY DAMAGED PARTS. IF DAMAGED DO NOT ATTEMPT INSTALLATION.

WARNING:

- Using sharp objects to clean the cooking grate or remove ashes will damage the finish.
- Using abrasive cleaners on the cooking grate or the grill itself will damage the finish.

WARNING: Use of any part that is not factory authorized will void your warranty and may be dangerous.



REPLACEMENT PARTS LIST AND EXPLODED ILLUSTRATION

BISON PREMIUM GRILL PARTS LIST				
EXPLODED ILLUSTRATION ITEM #	BULL PART #	DESCRIPTION	QTY	WARRANTY PERIOD SHOWN IN YEARS
1	88703	BISON PREMIUM INSERT ASSEMBLY	1	5
2	88704	BISON PREMIUM CHARCOAL BED BRACKET	1	1
3	88705	BISON PREMIUM CHARCOAL GRID BRACKET	1	1
4	88708	CHARCOAL GRID ASSEMBLY PLATE	2	1
5	88706	BISON PREMIUM CHARCOAL GRID	3	1
6	88707	BISON PREMIUM CHARCOAL GRID FRAME	3	1
7	16517	COOKING GRATE	4	LIFETIME
8	88701	BISON PREMIUM HOOD - REAR	1	1
9	88700	BISON PREMIUM HOOD - FRONT	1	1
10	16509	TEMPERATURE GAUGE	1	1
11	16673	TEMPERATURE GAUGE BEZEL	1	1
12	67004	LID HANDLE CENTER BAR	1	1
13	16522	LID HANDLE END CAP	2	1
14	67007	WARMING RACK	1	1
15	88702	BISON PREMIUM HOOD AIR VENT BUTTERFLY DAMPER	2	1
16	88711	BISON PREMIUM GREASE/ASH TRAY	1	1
17	67027	ASH PAN DAMPER	1	1
18	88709	BISON PREMIUM HEIGHT ADJUSTMENT BOLT	1	1
19	88710	BISON PREMIUM HAND CRANK	1	1

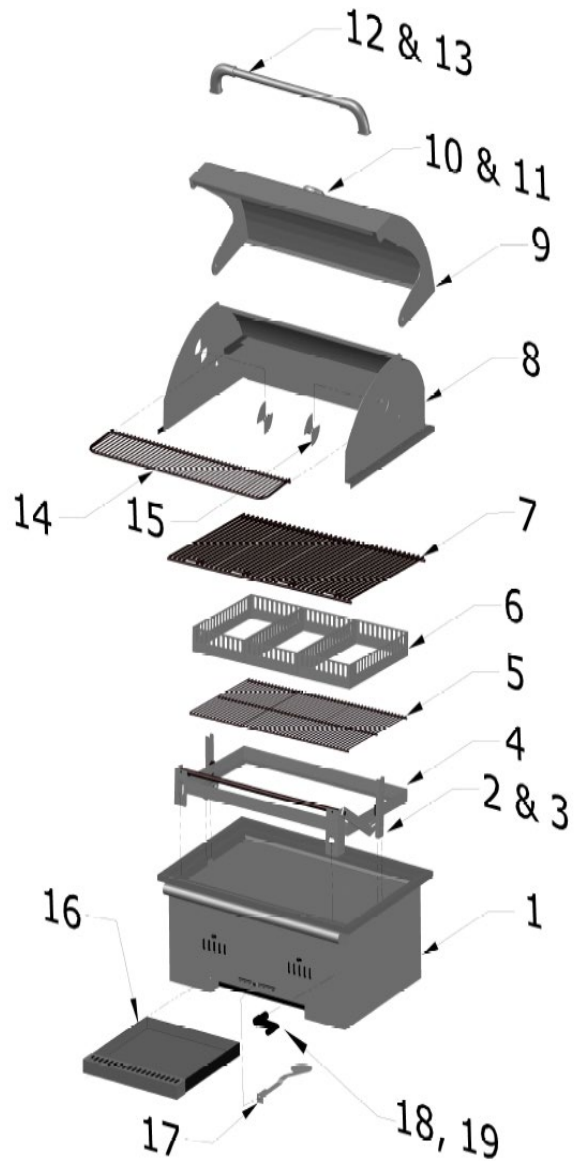

WARNING: Use of any part that is not factory authorized will void your warranty and may be dangerous.



Warranty Policy

LIMITED WARRANTY ON BULL OUTDOOR PRODUCTS, INC., PRODUCTS

THIS LIMITED RIGHTS, WHICH VARY FROM STATE TO STATE.

THIS LIMITED WARRANTY CAN ALSO BE FOUND ON OUR WEB SITE AT:

<https://www.bullbbq.com/support-warranty> (United States Customers)

<https://bullbbq.eu/customer-care/#warranty-registration-form> (International Customers)

AND IN THE OWNER'S/INSTALLATION MANUAL THAT WE PROVIDE WITH OUR PRODUCT.

THIS LIMITED WARRANTY IS SUBJECT TO THE EXCLUSIONS, CONDITIONS AND LIMITATIONS SET FORTH BELOW.

ANY IMPLIED WARRANTIES IMPOSED BY LAW, INCLUDING WITHOUT LIMITATION THE IMPLIED WARRANTIES OF MERCHANTABILITY AND FITNESS FOR A PARTICULAR PURPOSE, ARE LIMITED IN DURATION TO THE DURATION OF THIS EXPRESS LIMITED WARRANTY. SOME STATES DO NOT ALLOW LIMITATIONS ON HOW LONG AN IMPLIED WARRANTY LASTS, SO THE ABOVE LIMITATION MAY NOT APPLY TO YOU.

WHO MAY USE THIS WARRANTY?

BULL OUTDOOR PRODUCTS, INC. located at address 1011 East Pine St. Lodi, CA. 95240

("we") extend this limited warranty only to the consumer who originally purchased the product ("you") at the original site of delivery or installation. It does not extend to any subsequent owner or other transferee of the product. It does not apply to products installed in any rental, commercial or non-residential application. Examples of excluded applications include, but are not limited to day care centers, schools, bed and breakfast centers, churches, private clubs, fire stations, club houses, common areas in multi-family dwellings, restaurants, hotels, nursing homes, food service locations and institutional food service locations.

WHAT DOES THIS WARRANTY COVER?

This limited warranty covers defects in materials and workmanship of the product and product components identified below for the Warranty Periods defined below.

WHAT IS THE PERIOD OF COVERAGE?

This limited warranty starts on the date of your purchase and lasts for the time period or time periods specified above (the "**Warranty Period**"). The Warranty Period is not extended if we repair or replace the product. We may change the availability of this limited warranty at our discretion, but any changes will not be retroactive.



Warranty Policy (Continued)

Grilling/Pizza Accessories and Grill Covers DO NOT include a warranty period.

Grill Warranty Periods

The following parts are covered for **1 year** on all our current gas grill models:

- The lid, control panel, grease tray, bezels, knobs, temperature gauge, valves, regulator, flex tubes, rotisserie burner, transformer, and all components of the lighting system.

The following parts are covered for **3 years** on all our current gas grill models:

- The manifold, handle end caps, flame tamers, heat shields, and warming rack.

The following parts are covered for the **lifetime** on all our current gas grill models:

- Insert assembly and the grates.

The warranty period for the grill burners varies by type:

- Cast stainless steel burners - **Lifetime**
- Welded stainless steel burners - **5 years**
- Porcelain coated burners - **3 years**

The warranty period for the charcoal grill is **1 year** on all parts, except for the insert assembly, which is covered for **5 years**.

Component Warranty Periods

All the parts for our components /grill carts/refrigerators/kegerators/drawers/doors/refrigerator frames/grill jackets/finishing frames/ice chest/sinks/bar center are covered for **1 year** with these exceptions:

• Power Burner

- The insert/grates are **lifetime** covered parts.
- The manifold/burner is covered for **3 years**.

• Searing Station/Slide in Double Sideburner

- The grates are covered for **lifetime**.
- The insert for **5 years**.
- The manifold for **3 years**.

• Single Sideburner

- The grates are covered for **5 years** and
- The burner for **3 years**.

• Sidekick

- The burner is covered for **3 years**.

Pizza Ovens/Islands/Fire Features Warranty Periods

- All the parts and construction materials are covered for **1 year**.



Warranty Policy (Continued)

WHAT DOES THIS WARRANTY NOT COVER?

This limited warranty does not cover any damage due to:

- Transportation.
- Storage
- Improper installation or use
- Use on improper fuel/gas supply.
- Failure to follow the product instructions or to perform any preventive maintenance.
- Modifications.
- Unauthorized repair.
- Normal wear and tear, rust, corrosion, oxidation, or discoloration.
- External causes such as accidents, abuse, or other actions or events beyond our reasonable control.

WHAT OPTIONS ARE OFFERED BY BULL OUTDOOR PRODUCTS UNDER THIS WARRANTY?

With respect to any defective product claim made during the Warranty Period, we will, in our sole discretion:

- Replace such product (or the defective part) free of charge or refund the purchase price of such product.

WHAT IS EXCLUDED BY BULL OUTDOOR PRODUCTS UNDER THIS WARRANTY?

- We will not pay for shipping charges for repaired or replacement parts, or for any labor or labor related charges.
- We will not pay for any accessory products or ancillary products purchased by you for use in connection with the product.

HOW DO YOU NOTIFY BULL CUSTOMER SERVICE OF A POTENTIAL WARRANTY ISSUE?

Our Customer Service is ready to help. Here's how to reach us:



By Phone (800) 521-2855 Monday through Friday from 8:00 a.m. to 5:00 p.m. (EDT)



To submit a warranty claim on-line or message go to <https://www.bullbbq.com/support-warranty>

LIMITATION OF LIABILITY

THE REMEDIES DESCRIBED ABOVE ARE YOUR SOLE AND EXCLUSIVE REMEDIES AND OUR ENTIRE LIABILITY FOR ANY BREACH OF THIS LIMITED WARRANTY. OUR LIABILITY SHALL UNDER NO CIRCUMSTANCES EXCEED THE ACTUAL AMOUNT PAID BY YOU FOR THE DEFECTIVE PRODUCT, NOR SHALL WE UNDER ANY CIRCUMSTANCES BE LIABLE FOR ANY CONSEQUENTIAL, INCIDENTAL, SPECIAL OR PUNITIVE DAMAGES OR LOSSES, WHETHER DIRECT OR INDIRECT.

SOME STATES DO NOT ALLOW THE EXCLUSION OR LIMITATION OF INCIDENTAL OR CONSEQUENTIAL DAMAGES, SO THE ABOVE LIMITATION OR EXCLUSION MAY NOT APPLY TO YOU.